

Lowering Financial Inclusion Barriers With a Blockchain-Based Capital Transfer System

Whitepaper

Alexi Lane¹, Benjamin Leiding², and Alex Nort³

¹ Everex, Singapore
alexi@everex.io

² Chaindrium, Göttingen, Germany
mail@chaindrium.com

³ Large-Scale Systems Group, Tallinn University of Technology, Tallinn, Estonia
alex.norta.phd@ieee.org

Abstract. Transferring money and gaining access to credit across international borders is still complicated, time consuming and expensive. Existing money transfer systems suffer furthermore from long lines, exchange rate losses, counter-party risks, bureaucracy and extensive paperwork. An estimated two billion adults are unbanked and with no, or limited access to financial services. Providing workable financial services to this population is often tagged as a key step towards eliminating world poverty and bootstrapping local economies. Everex focuses on easing the financial inclusion problem by applying blockchain technology for cross-border remittance, online payment, currency exchange and micro lending, without the volatility issues of existing, non-stablecoin cryptocurrencies. This whitepaper fills the gap in the state of the art by presenting a blockchain-based capital transfer system that aims to lower financial inclusion barriers and provide financial services to the unbanked. We present the advantages of the system, outline the requirements and goals, as well as the architecture of the Everex financial eco-system. In addition, we present the results of an Everex remittance system case-study that involves over 100 migrant workers from Myanmar.

Keywords: financial inclusion, lending, remittance, payment, cash transfer, blockchain, smart contract, ethereum, mobile payment, stablecoin, cryptocash

1 Introduction

Advances in transportation, mass migration, the rise of the Internet and mobile devices as well as the rise of multinational corporations drive globalization and cross-border integration [10][31][52]. Nevertheless, sending money across international borders is still complicated and expensive, with charges per transaction averaging 7.45% [50]. Existing remittance- and transfer systems suffer from long lines, waiting times, exchange-rate losses, counter-party risks, bureaucracy and

extensive paperwork. At the same time, an estimated two billion adults are without access to bank accounts [13], thereby excluding them from basic and daily services such as payments, remittances and access to credit. Even more problematic than the missing access to cross-border payments is the exclusive offering of cross-border lending to big institutional clients by banks. Those unserved customers participating in the physical cash-based, or *informal* economy are a large-scale audience, if given better tools. Providing financial inclusion to those more than two billion adults currently excluded from the global financial system, has a large untapped potential, both for economic development and business profit. Providing novel financial solutions to unbanked populations is essential for poverty elimination and growing economies [49]. Furthermore, people work and travel internationally, especially 250 million migrant workers [54], tourists, permanent travelers, expats, digital nomads and international students, who effectively become underbanked abroad. Having no local credit history, or bank accounts renders access to credit and transfer of money challenging. Moreover, undocumented income is not available to build a credit reputation.

To achieve financial inclusion of the unbanked, or underbanked adults, Everex proposes the novel concept of *Cryptocash*. Cryptocash is a cryptocurrency, where each unit has its value pegged to, and a name based on, the fiat currency it represents, e.g., US-Dollar (USDEX). Cryptocash balances are provably underwritten by balances held in accounts of financial entities, or other trusted third-party cash custodians. Users convert their paper-, or digital fiat-currencies to Cryptocash at their local bank branch, or at currency exchanges and transfer them via a blockchain peer-to-peer (P2P), using wallets kept on mobile phones, or online browsers. We focus on solving the financial inclusion problem by applying blockchain technology for cross-border remittances, online payments, currency exchange and micro lending using Cryptocash, without the volatility issues of existing, non-stablecoin cryptocurrencies. This whitepaper addresses the detected gap by introducing Everex's blockchain capital transfer system based on Cryptocash and thereby answering the question of how to enable money transfer with easy capital access at virtually no costs without being limited to a domestic market? In order to answer this question with a separation of concerns, we pose the following sub-questions: What are the goals and requirements of such a system? What is the architecture of a blockchain-based financial eco-system? What are the system-engagement processes for the stakeholders?

The remainder of this whitepaper is structured as follows: Section 2 introduces Cryptocash in detail, a micro lending running case and background literature. Section 3 focuses on defining functional- as well as quality goals, stakeholders and the requirements of the Everex capital transfer system. In Section 4, the architecture of the system is derived from the results of Section 3 and explained in detail. Section 5 expands on the system-engagement processes for the stakeholders. Evaluation results of an Everex case-study conducted in Thailand together with over 100 migrant workers from Myanmar, are presented in Section 6. Finally, Section 7 concludes this whitepaper and provides an outlook on future work.

2 Financial Inclusion in Practice - A Micro Lending Running Case

In Section 2.1 the cryptocurrency Cryptocash, that is used by all Everex services, is introduced in detail. Afterwards, Section 2.2 introduces a real-life running case of micro lending as an example for financial inclusion in order to illustrate a use-case of Everex’s blockchain-based capital transfer system. Finally, Section 2.3 presents further related literature to prepare the reader for subsequent sections.

2.1 Cryptocash

The main-component that enables the Everex capital transfer system is Cryptocash, a fiat-pegged fully reserved stablecoin issued by a decentralized and federated network of cash custodians and underwriters. Cryptocurrencies pegged by fiat currencies, such as Everex’s Cryptocash, are commonly referred to as *stablecoins*. The idea of a stablecoin is based on the assumption that low purchasing power volatility is the main driver behind mainstream demand for a cryptocurrency [17]. Cryptocash units have its value pegged to, and a name based on, the fiat currency it represents, e.g., US-Dollar (USDEX). Cryptocash tokens are provably underwritten by balances held in accounts of financial entities, or other trusted third-party cash custodians. Figure 1 depicts the main entities and processes of the Cryptocash eco-system. As illustrated in Figure 1, the user Alice converts her paper-, or digital fiat-currencies to Cryptocash at her local bank branch, or at currency exchanges and transfers the Cryptocash coins via a blockchain to Bob. Afterwards, Bob can either convert the received Cryptocash units back to any selected fiat currency, or use Cryptocash for further remittance-, and payment transactions. Moreover, Cryptocash tokens can also be converted from one unit to another, e.g., cryptoUSD (USDEX) to cryptoBaht (THBEX). It is also possible to deposit and redeem Cryptocash via an independent network of exchanges within a country using bank to bank transfers, an ATM network, or in cash. For individuals cash-in and wallet-to-wallet transactions are free of charge, but a small fee is charged when exchanging Cryptocash to fiat currencies. In the case of businesses, a 1% fee is charged for accepting Cryptocash payments, but withdrawal is free of charge.

Cryptocash is implemented on the Ethereum [53] blockchain and uses Solidity⁴ as a smart contract languages. In contrast to Bitcoin, Ethereum provides a publicly available and distributed ledger system, and incorporates Turing-complete programming languages on the protocol-layer to realize smart contract capabilities. Smart contracts are, “orchestration- and choreography protocols that facilitate, verify and enact with computing means a negotiated agreement between consenting parties” [9]. Participants establish binding agreements and deploy applications on the blockchain using such smart contracts in order to provide certain services - in the context of Everex, services for financial inclusion. Each Cryptocash token, e.g., USDEX, is implemented as an independent smart

⁴ <https://solidity.readthedocs.io/en/develop/>

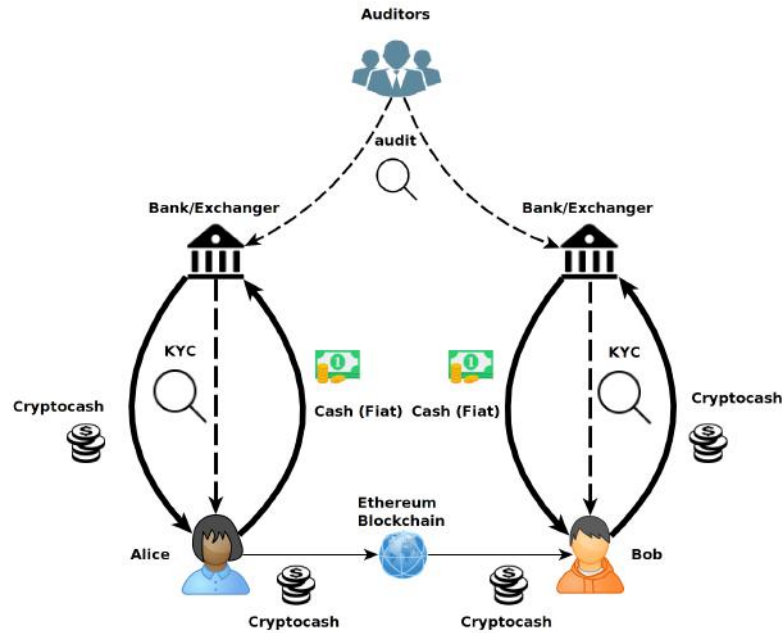

Fig. 1: Overview on the Cryptocash eco-system.

contract based on the ERC20 token standard⁵. During the initial setup-phase of the capital transfer system, those token contracts are controlled by Everex for security reasons, while we learn the customers behavior and demand for our services. During later project stages, the contract control is delegated to a third party, e.g., a public entity, or a regulatory body. All token contracts are publicly available and open for audits. Since published contracts cannot be changed anymore, a token contract governance system allows to create child-contracts, approved and voted for by the system stakeholders, thereby updating the rules of the corresponding parent contracts. The Cryptocash token smart contracts are independent from Everex wallets and therefore, external service providers can build their own ERC20-compliant wallets and conduct Cryptocash-based transactions.

Besides converting Cryptocash tokens to fiat money and vice versa, banks and exchanges depicted in Figure 1 also handle so called *know your customer* (KYC) processes [18], thereby identifying and verifying the identity of users. The resulting information are used to adhere to legal obligations and risk management as well as credit scoring calculations. The financial guarantee used as underlying reserves for issued Cryptocash tokens are completely transparent and constantly audited by independent auditors. In addition, the decentralized and

⁵ https://theethereum.wiki/w/index.php/ERC20_Token_Standard

federated nature of the involved financial entities also eliminates the risk of a central point of failure.

2.2 Micro Lending Running Case

Given the absence of traditional sources of funding provided by banks, the task of acquiring a loan, or getting access to capital for unbanked individuals and entrepreneurs is difficult [6]. Micro lending is an alternative to traditional financing [3] and describes the practice of granting small loans to individuals, entrepreneurs, or small and medium-sized enterprises (SMEs) who intend to start a business, or are in need of extra cash. Figure 2 illustrates the data flow of such a micro lending scenario. A micro lending contract is triggered upon the request of a small loan by a borrower. The loan is requested in any of the available Cryptocash currencies, e.g., USDEX. Cryptocash units are distributed to the borrower by a lender after passing approval and due diligence processes. The borrower can convert the received Cryptocash loan to fiat money if required after receiving the loan.

The lifecycle of a micro lending contract is divided into the following stages: a) preparatory, b) negotiation, c) contract execution d) rollback and e) a contract expiry stage. During the preparatory stage, information about the involved entities, such as names and addresses are incorporated into the contract. In addition, the conditions of the requested loans are formally defined by specifying, e.g. the size of the loan, chosen currency, runtime and interest rates. The conditions of the requested loan mainly depend on information available to the lender, such as financial data gathered during previous interactions and transactions, personal data and information from social media. In case the borrower and the lender agree on the negotiated conditions, both parties sign the contract and express their approval - if no agreement is reached, a contract rollback is triggered. After signing the agreement, the contract execution phase is triggered and the lender transfers the loan to the borrower as illustrated in Figure 2. Afterwards, the lender can use the loan to expand, or start a business.

The micro lending contract terminates, or expires either after the defined loan timespan, or when the contract is prematurely terminated. The borrower pays back the loan either in separate rates, or as a whole, depending on the defined conditions. In addition, the lender also receives a fee, or an interest rate from the borrower for providing the loan. In case the borrower fulfills all his/her duties, the lender might provide a larger loan in the future based on the positive credit history of the borrower. Everex does not operate on the basis of P2P loans and instead invests its own aggregated capital to provide globally accessible credit services. Nevertheless, it is up to each Cryptocash owner to lend his/her own tokens to other users.

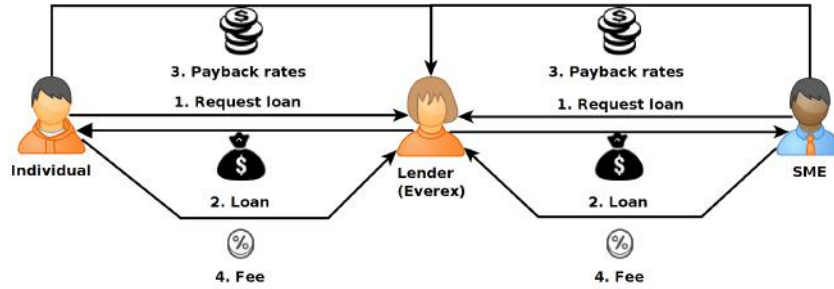

Fig. 2: Illustration of micro lending, either to individuals or SMEs.

2.3 Related Work and Supplementary Literature

A broad range of scientific literature focuses on the fundamentals of microfinance, e.g., [8][24][43][46]. Furthermore, several studies discuss the impact and results of these concepts in third world-, or development countries [1][34][44][55].

In recent years, several online-, or cellphone-based micro lending platforms such as Kiva⁶, Zidisha⁷, or M-Pesa's⁸ [21][23] M-Shwari emerged [45]. Those services connect lenders with borrowers from third world-, or development countries. Zidisha and Kiva provide crowd-sourced microfinance as well as cooperations in group lending [20][29]. Lenders register on Kiva's, or Zidisha's website and apply for a loan. Lenders can select from the list of applications for small loans and provide the required amount of money. The borrower invests a loan as intended and pays it back according to the negotiated conditions. In contrast to Kiva and Zidisha, M-Pesa focuses on cellphone-based money transfer, financing and micro lending services. Users deposit money into an account stored on their cellphones and transfer money using text messages to other users, e.g., merchants, service providers, or currency exchanges.

BTCJam⁹ further extends the online micro lending universe using cryptocurrencies [16]. Cryptocurrencies rely on public distributed ledgers, called blockchain, that record transactions without requiring a trusted central authority and instead, rely on a global consensus. Blockchain technology is most noticeably known for providing the foundation of the P2P cryptocurrency and payment system Bitcoin [32]. The blockchain concept spreads in popularity and serves as a basis for various applications and use-cases, e.g., managing digital identities on blockchain (e.g., Authcoin [26], or uPort¹⁰ [28]), digital-signing solutions [14], as a platform for Internet-of-Things (IoT) applications [7][27][41] and also in the finance sector [5][35].

⁶ <https://www.kiva.org/>

⁷ <https://www.zidisha.org/>

⁸ <https://www.safaricom.co.ke/personal/m-pesa>

⁹ <https://btcjam.com/>

¹⁰ <https://www.uport.me/>

A lifecycle management concept for smart contracts used to manage negotiations between decentralized autonomous organizations (DAO), similar to the negotiation in the micro lending running case of Section 2.2, is presented in [36][37]. In [39], a conflict-resolution lifecycle is presented that enables conflict-related exception- and compensation management during a decentralized collaboration. Conflicts can either be resolved in a disruptive, or calming manner, resulting in a contract termination or continuation. Specific modeling, management and resolution of conflicts between DAOs is described in [33]. The authors propose an ontology that models conflict types along with related exceptions that occur during the contract execution as well as negotiation and resolution strategies used for conflict management and resolution.

3 Functional Goals, Quality Goals, Stakeholders and Requirements of the Everex Capital Transfer System

We define the goals and requirements of the capital transfer system using one part of an Agent-Oriented Modeling (AOM) method [48], i.e., goal models. The AOM method is a socio-technical requirements-engineering approach used to model complex systems that consist of humans, devices, and software agents. We utilize the AOM goal model to capture the functional requirements of the Everex system in order to provide a better understanding of the modeled system and domain for both, technical- and non-technical stakeholders. As illustrated in Figure 3, an AOM goal model comprises three main elements used to capture the system requirements and goals. In system development, good requirements are characterized as follows [22][12]: First, they address one issue only and are completely specified without missing information. Furthermore, requirements have to be consistent and do not contradict itself, or in correlation with other requirements. In addition, a requirement must be atomic and without conjunctions [38]. Functional requirements are referred to as goals and depicted as parallelograms, whereas roles of involved entities are represented in form of sticky men. The group of non-functional requirements either refers to quality goals of the software system, depicted as clouds, or emotional goals depicted as ellipses. Functional requirements of the goal model are structured in a tree-like hierarchy with the root value proposition of the system at the top. Subsequently, the main goal is further decomposed into sub-goals. Each sub-goal represents an aspect for achieving its parent goal [30] and the goals are decomposed into multi-layered sub-goals until the lowest atomic level is reached. Roles, quality goals and emotional goals may be assigned to goals and are inherited to lower-level goals.

In addition to the commonly used notations elements, we introduce a new AOM element of a *shared goal* as illustrated in Figure 3. The *shared goal* notation element is used to model the affiliation of a specific functional sub-goal with multiple parent goals, meaning that they all share the specified functional requirement. The parent goals are attached either to the top, bottom or left side of the symbol, whereas the shared sub-goal is attached to the right side of the

symbol. Examples of this new notation element are provided in the refined AOM goal model presented in Figure 4.



Fig. 3: Extended AOM notation elements.

The following sections present the AOM goal model of the system using the modeling method described above. The resulting goal model is used in Section 4 to derive the capital transfer system architecture. Section 3.1 focuses on the top-level goal model, whereas Section 3.2 presents the refined goal model of the micro lending running-case.

3.1 Top-Level AOM Goal Model

The value proposition, provide blockchain-based micro-finance services, of the Everex system is depicted as the root of the AOM goal model in Figure 4. We split the complex value proposition into three sub-goals representing the three main services of the system: Lending-, payment- and remittance services. These goals are further refined and explained in Section 3.2.

We identify six quality goals of the value proposition that are inherited to all refining parts of the main goal. First, *scalable* describes the non-functional requirement of the Everex system to provide its financial inclusion services to a large quantity of entities. *Cost-effective* means that the users expenses for using the financial services should be substantially lower than existing solutions, e.g., the current cross-border remittance transaction prices averages at 7.45% [50]. In order to achieve this cost-effectiveness, the quality goal *highly-automated* refers to a high degree of process automation eliminating the need for human interaction in tedious and repetitive tasks. *Fast*, describes the provision time of the financial services. Lending, payment and remittances services of the Everex system are provided within a desirable response time. *Secure* service provision is crucial in the context of financial services, e.g., user accounts have to be protected from unauthorized access, personal data has to be stored in an encrypted manner, and so on. *Transparent* means that all transactions of the system are publicly auditable, thereby increasing its trustworthiness. Furthermore, we assign an additional quality goal to the *pay* sub-goal. *Convenient* means that Everex-based payments should be widely accepted, and available and in addition have low access barriers.

3.2 Refined AOM Goal Model

The further refined AOM goal model is also illustrated in Figure 4. In this section, we focus on a detailed explanation of the *Lend* sub-goal, following the micro lending running case introduced in Section 2.2. Micro loans are provided by lenders and requested by users of the system. Borrowers can request loans either in a foreign-, or their domestic currency. A credit-scoring algorithm determines the borrower’s creditworthiness based on input data such as financial-, personal-, or social-media data. Financial data refers to the user’s transaction history on the public blockchain, e.g., past loans, payments, or remittance transactions. Information on personal-, or social-media data is extracted from the user’s mobile phone, or other devices. Based on the credit-scoring results, lender and borrower negotiate the lending contract conditions, e.g, size of loan, or runtime and interest rates. In case borrower and lender agree on the negotiated conditions, both parties sign the contract and express their approval. Afterwards, the lender transfers the loan to the borrower. During the contract runtime, the borrower pays interest rates, or a fee, and monthly rates to reduce the remaining loan size.

As denoted in Figure 4, the user can also convert the Cryptocash micro loan to another Cryptocash currency, or a fiat currency using an exchange. Nevertheless, the loan is paid back in the Cryptocash currency used to issue the loan. For each currency exchange transaction, a small fee is paid to Everex. Note that the *currency exchange* sub-goal is a shared sub-goal of *Lend*, *Pay* and *Remit*, meaning that also payment-, and remittance transactions can be converted to other Cryptocash-, or fiat currencies and result in a service fee paid to Everex. The sub-goal *pay* is further refined into *selling* and *buying* from, or to merchants. In the context of this model, a merchant can also be another user offering a service, or good. The *remit* sub-goal consists of selecting a currency and recipient for the remittance process, followed by transferring the specified quantity of Cryptocash to the recipient. Again, the transferred Cryptocash tokens can be exchanged (shared goal) and a service fee is paid to the system operator.

Next, we present the Everex system architecture and specifications derived from the presented AOM goal model of this section.

4 Capital Transfer System Architecture

This section focuses on deriving the abstract business architecture of the Everex capital transfer system from the AOM goal model and the requirements of Section 3. We deploy a service-oriented architecture (SOA) approach, with well-defined and self-contained components that provide a specified set of services [15][42]. A technology-agnostic UML-component-diagram representation is chosen to illustrate the system architecture [2][47]. Figure 5 shows the UML notation elements used to illustrate the system architecture. Components are represented as rectangular boxes and labeled either with the keyword *component*, or with the component icon in the right-hand upper corner. Components are refinable with sub-components and implemented by one, or more classes, or

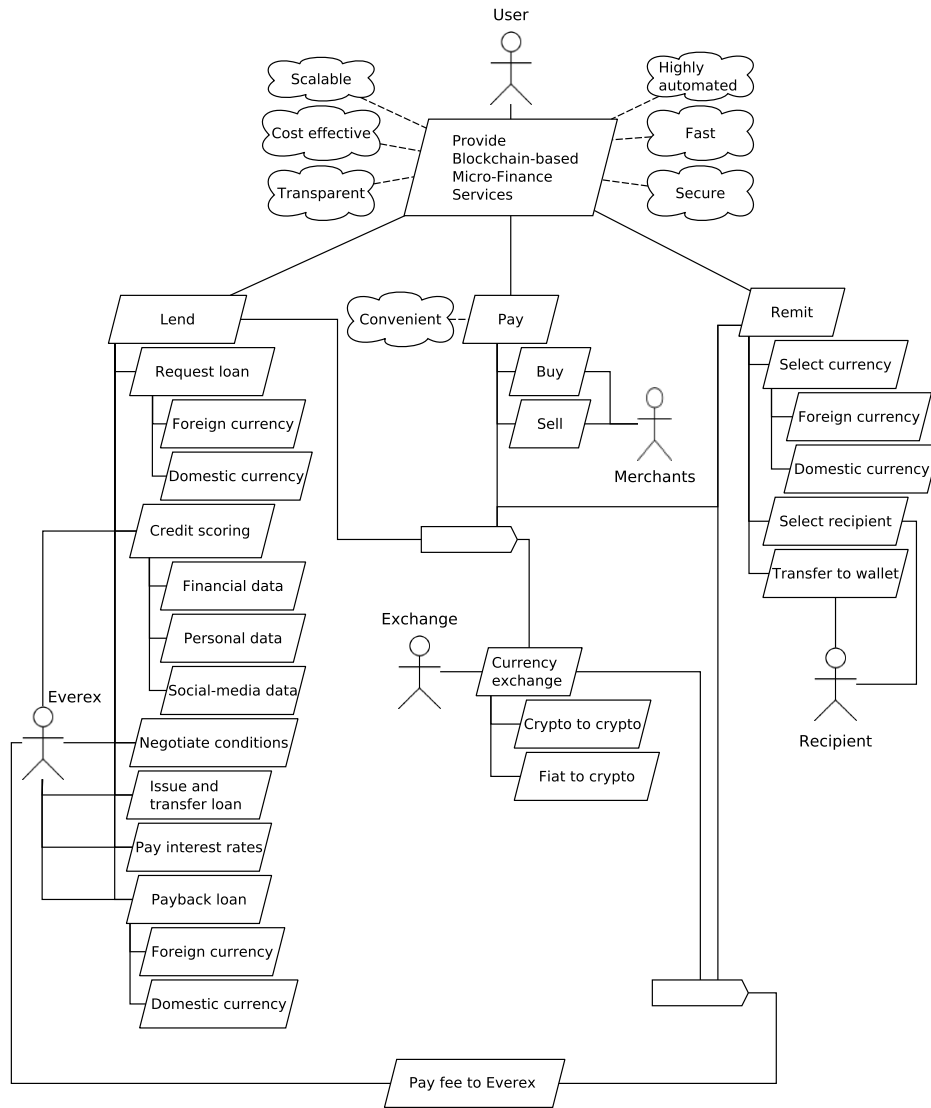

Fig. 4: Refined goal model of the Everex capital transfer system.

objects. Components are reusable pieces of system functionality and communicate via interfaces. As illustrated in Figure 5, components provide interfaces, or require interface in order to realize their functionalities. Ports we depict as small squares and are attached to the border of components. They are used to expose required and provided interfaces of a component. Ports may specify inputs and outputs as they can operate uni-, or bi-directionally [2][47]. Furthermore, similarly to the AOM goal model from Section 3, sticky men are used to depict the roles of involved entities and their interactions with the system. Finally, we use green and blue colorings of notation elements to illustrate different stages of implementation. Green colored components are already available and working in production. Blue colored notation elements refer to components that have not been implemented yet but are part of the system architecture.

The remainder of this section shows a top-down model representation of the derived system architecture. First, Section 4.1 provides an abstract overview on the highest-level of the system architecture, followed by a refined illustrations of selected architecture components in Section 4.2.

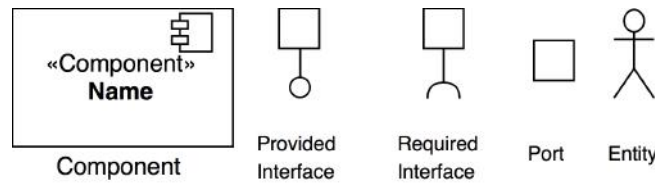

Fig. 5: UML-component diagram notation elements.

4.1 Architecture Overview

The highest architecture abstraction level is depicted in Figure 6. The representation is divided into two distinct packages, e.g, the *Blockchain* package and the *Everex-System* package. In UML, packages are used “to group elements, and provide a namespace for the grouped elements” [47]. In the context of this architecture illustration, packages are used to provide a separation of concerns between the external blockchains, e.g., the Bitcoin-, and Ethereum blockchain, and the capital transfer system components. Everex hosts its own Ethereum blockchain service nodes in order to realize and provide the services of its capital transfer system such as creation, reading and confirmation of transactions as well as management of the Everex smart contracts that control the Cryptocash tokens.

The *Everex-System* package consists of four components: The *Account Management* component, the *Everex-Services* component, the *Ethereum-Parser* application and a database component that stores a parsed version of the Ethereum blockchain. The *Account Management* component is the first point of contact

for each user. Users register an account and create a personal Cryptocash wallet. Wallets are stored on the blockchain, whereas user data is stored in a database inside the *Account Management* component. The same component is also used to authenticate entities involved in services provided by the *Everex-Services* component and ensures accountability. Services and user interactions that trigger, or create blockchain transactions are also handled by this component that interacts with the blockchains using ports and interfaces. The *Account Management* component receives transactions from Everex services via the *TX API*. After further processing, these transactions are pushed to the specified blockchain via the provided interfaces.

The *Everex-Services* component comprises all services provided by the capital transfer system. Users, merchants and lenders as well as licensed financial institutions interact with this component using ports and interfaces. Users utilize the services and merchant’s receive-, or send payments. Financial institutions focus on the exchange of fiat currencies to the respective Cryptocash equivalents. Everex’s micro lending service is handled using the lending API. The *Account Management* component is utilized to authenticate users and manage resulting transactions that are logged on the blockchain.

The *Ethereum-Parser* application is used to index and track all Cryptocash transactions on the Ethereum blockchain and store them in the database component. The parsed information is used for the billing of Everex services and the calculation of credit scores of borrowers.

4.2 Selected Architecture Refinements

The following section focuses on a selection of refined architecture components. First, Figure 7 presents a detailed view on the *Everex-Services* component. Afterwards, Figure 8 further refines the *Lending* component that is part of the *Everex-Services* component, thereby enhancing the architectural-understanding of the micro lending running-case of Section 2.2. Figure 7 illustrates the four service components of the capital-transfer system: The *Retail-Payment* component, the *Remittance* component, the *Exchange* component and the *Lending* component, mapping to the functional goals illustrated earlier in Figure 4. A further component, handles transaction related processing functionalities, e.g., the *Prep-TXs* component.

The *Retail-Payment* component and the *Remittance* component as well as the *Exchange* component are structured similarly. Each of these components is connected to the *User API* and the *Authentication* interface. In addition, each of them contains an initialization component that handles preparatory tasks to enable the specific remittance, payment, or currency conversion service. In the context of the *Remittance* component, this includes identifying and authenticating the sender and receiver, selecting a currency for the remittance process as well as preparing all information for the transaction triggered by the remittance process. Similar preparatory tasks are processed in the context of the *Retail-Payment* component and the *Exchange* component. Afterwards, for each of the three components, the prepared information is further processed in the *Prep-TXs*

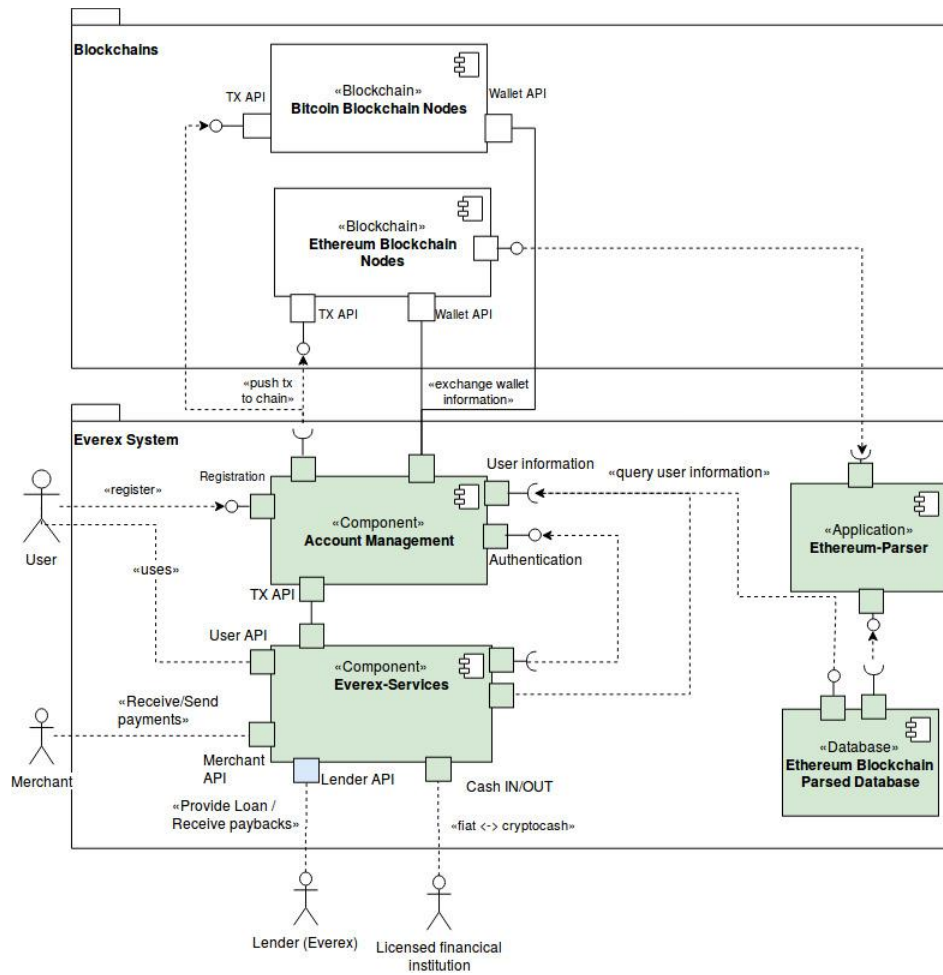

Fig. 6: Abstract high-level overview of the capital transfer system architecture.

component and an Ethereum transaction is created executing the desired services. The prepared transaction is then executed in conjunction with the *Account Management* component and pushed to the blockchain.

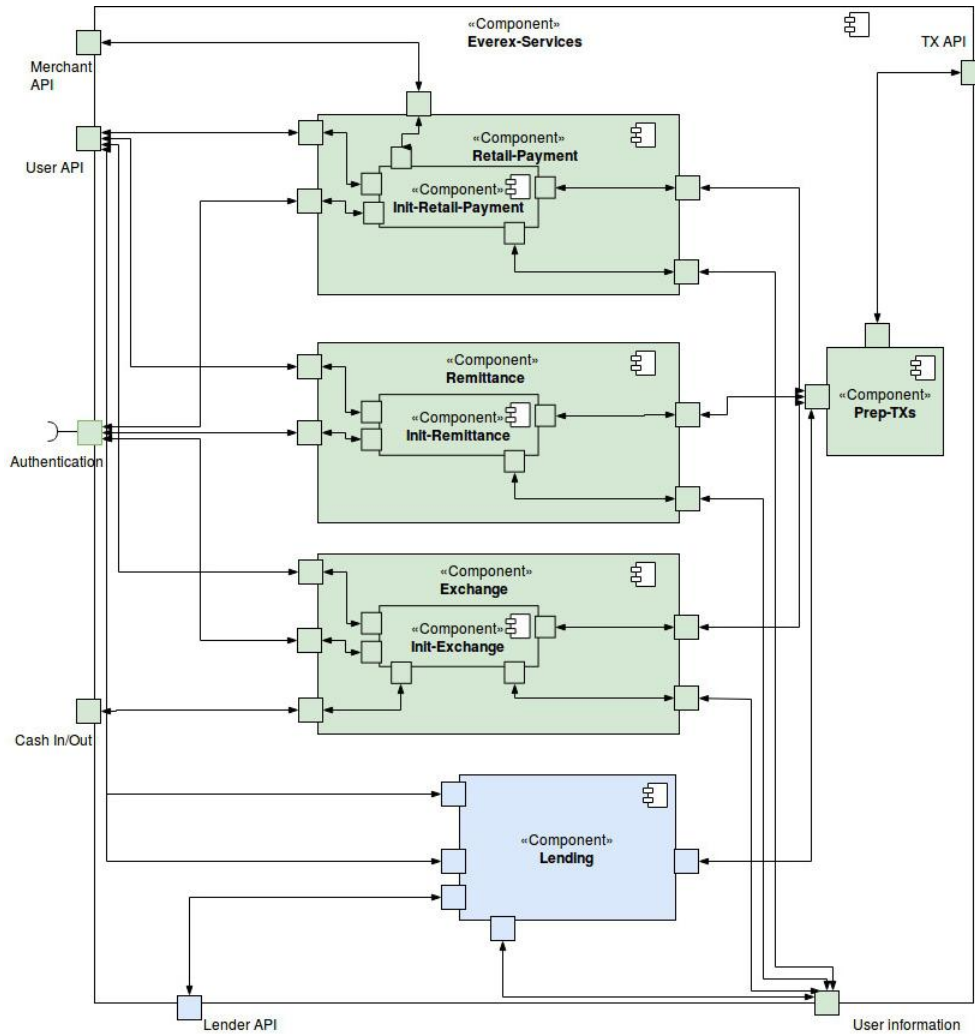

Fig. 7: Refined illustration of the *Everex-Services* component.

The *Lending* component of Figure 7 is illustrated in a refined representation in Figure 8. As mentioned earlier, the blue color of the component indicates that it has not been implemented yet but is an essential part of the Everex financial eco-system. The component is accessed by the user in the same way as the other three service components using the *User API*. In addition, users are authenti-

cated using the corresponding API of the *Account Management* component, and resulting transaction information are forwarded to the *Prep-TXs* component. The *Lending* component itself consists of four sub-components: The *Init-Lending* component, the *Credit-Scoring* component, the *Contract-Negotiation* component and the *Lending-Execution* component.

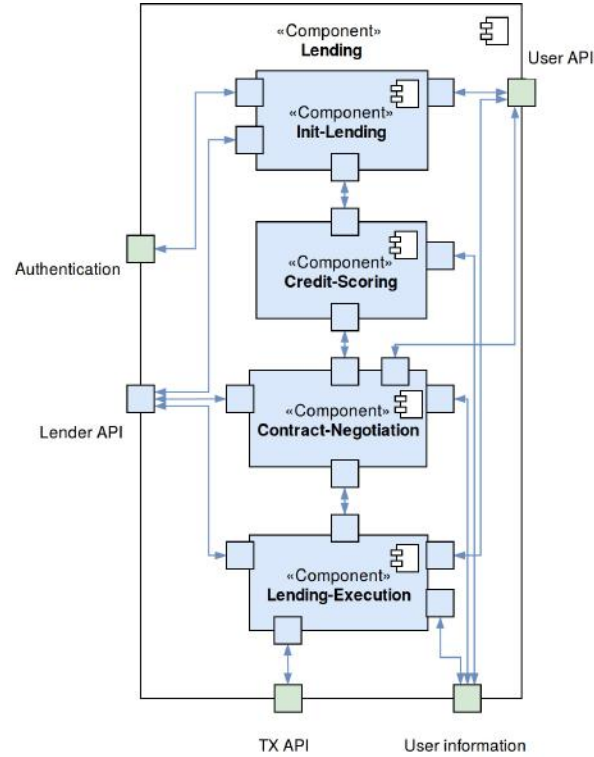

Fig. 8: Refined illustration of the *Lending* component.

The *Init-Lending* component corresponds to the preparatory stage of the lifecycle of a micro lending contract as introduced in Section 2.2. During the preparatory stage, all involved entities are authenticated and entity-related information such as names and addresses, are collected and specified using the *User Information* port. In addition, the properties of the requested loans are gathered, e.g, the requested size of the loan, chosen currency and requested runtime. The *Credit-Scoring* component calculates a credit score of the borrower based on information available to the lender, such as financial data gathered during previous interactions and transactions, personal data and information from social media using the *User Information* port. The negotiation stage of the micro lending contract maps to the functionalities provided by the *Contract-Negotiation*

component. Lender and borrower negotiate the loan conditions based on the specification of the loan requested by the borrower and the credit-scoring results. In the case that borrower and lender agree on the negotiated conditions, both parties sign the contract and express their approval. If no agreement is reached, a contract rollback is triggered. After signing the agreement, the contract execution phase is triggered and the *Lending-Execution* component takes over the micro-lending contract execution. The required information are transferred to the *Prep-TXs* component and the lender transfers the loan to the borrower as illustrated earlier in Figure 2. Afterwards, the lender can use the loan to expand, or start a business. The micro lending contract termination, or expiration is also managed by the *Lending-Execution* component. The borrower pays back the loan either in separate rates, or as a whole, depending on the defined conditions. In addition, the lender also receives a fee, or an interest rate from the borrower for providing the loan. The lender of our running case provides the loan and receives his/her paybacks using the *Lender API*. In case the borrower fulfills all his/her duties, the lender might provide a larger loan in the future based on the positive credit history of the borrower.

Next, in Section 5 we present the system-engagement processes of the capital transfer system using the micro lending running-case.

5 System-Engagement Processes

The Everex system automates and simplifies financial service processes, thereby easing the financial inclusion of its benefiting stakeholders. An integral part of the capital transfer system is the lending system besides the remittance-, payment- and currency-exchange functionalities. The processes that form the lending system are the result of collaborating tasks and subprocesses. For example, users might receive their payroll in Cryptocash due to missing access to bank accounts, perform cross-border remittance and send money to their families. In addition, they use Cryptocash for regular payments. The resulting financial transaction data are available on the blockchain and used for individual credit scoring. The results of these processes provide information for the lending system and specify certain constraints, e.g, interest rates, size of available loan. Based on the chosen micro lending running case, we outline the exemplary detailed processes and benefits of involved stakeholder, e.g, for lending, payback and paying interests, stakeholder involvement, exception- and escalation management, conflict-resolution management, profit distribution, and so on. Further processes of the system concern currency exchange, micro-payments, insurance, crowdlending. The processes are represented using Business Process Model and Notation (BPMN) [4].

Consequently, Section 5.1 details the BPMN representation of the micro lending running case, followed by Section 5.2 that details the credit scoring mechanism of the micro lending process. Finally, Section 5.3 covers the EVX token value proposition.

5.1 Micro-Lending Process

In the following, we map the goal model of Section 3 and the system architecture of Section 4 into a business-process model for projecting the micro lending running case. The modeling notation used in the following Figures 9 - 11 is the business process model and notation BPMN [4]. Figure 9 illustrates the the micro lending business process from an abstract high-level point of view, whereas Figure 10 and Figure 11 present selected refinements of specific sub-processes of the micro lending business process. The green circle denotes the start of a process and the red circle the end. Simple rectangles denote tasks, or processes and rectangles with an additional plus sign are so called subprocesses. A subprocess hides lower-level business-process details.

As shown in Figure 9, the micro lending process is initiated upon a loan-request by a user. The request triggers a non-interrupting message send to the lender initializing the lending process from the lender's point of view. These two processes correspond to the *Init-Lending* component of Figure 8 and jointly trigger the lending contract sub-process, which is denoted by the *exclusive* symbol.

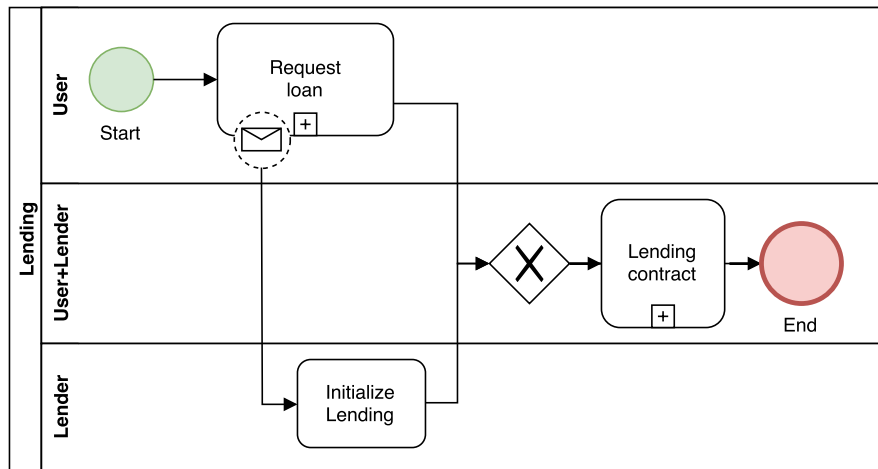

Fig. 9: BPMN representation of the micro-lending process.

The hidden lower-level processes of the *lending contract* subprocess are detailed in Figure 10. Everex's lending contract process structure is closely related to the smart-contract lifecycle management of Qtum [9] and Agrello [40], which is based on the formal smart-contract lifecycle as presented in [25][36][37][39]. The *lending contract* subprocess starts with the preparatory stage that is further refined in Figure 11. All involved entities are authenticated and entity-related information such as names and addresses, are collected and specified. In addition, the properties of the requested loans are gathered, e.g. the requested size of the

loan, chosen currency and requested runtime. Furthermore, the credit-scoring calculations are part of this process. Note the additional interrupt-events, depicted as envelopes in closed circles, that can be triggered during each of the three first sub-processes. An interrupt event cancels the current task immediately and afterwards continues with the attached task, or process. In the context of the preparatory stage, it is the *premature termination* task that is called if any of the three sub-processes fail and a rollback is triggered.

As part of the *Negotiation* subprocess, the lender offers a loan specified by certain constraints and the user either accepts, or declines the offer. Alternatively, a renegotiation based on changed input parameters, e.g., the loan size, is triggered. Assuming a mutual agreement, the *Contract execution* subprocess is triggered mapping to the *Lending-Execution* component in the system architecture of Figure 8. The lender transfers the money to the borrower who pays back the loan either in separate rates, or as a whole, depending on the defined conditions. Moreover, the lender also receives a fee, or an interest rate from the borrower for providing the loan in Cryptocash. In case the borrower fulfills all his/her duties, the lender might provide a larger loan in the future based on the positive credit history of the borrower. In case of contract violations of any party a disruptive rollback might be triggered depending on the violation, e.g., not paying interest rates or missing payments. Note that business processes as described above can be mapped onto the smart-contracting language Solidity for blockchain-based enactment [51]. Solidity is used for all Everex smart contracts.

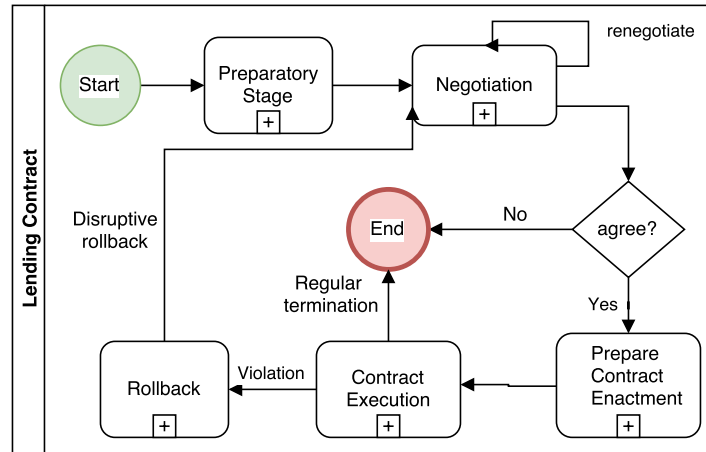

Fig. 10: Refined BPMN representation of the micro lending contract negotiation process (Adapted from [9]).

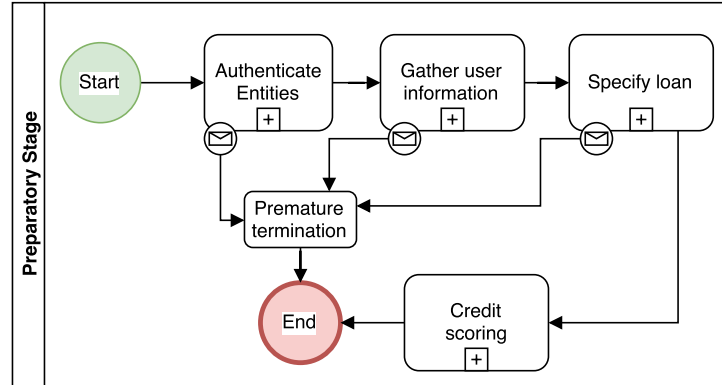

Fig. 11: Refined BPMN representation of the preparatory stage of the micro lending contract negotiation process.

For the sake of simplicity, we skip further refinements of additional subprocess and instead briefly introduce a more detailed presentation of the credit scoring process, as depicted in Figure 11, in the subsequent Section 5.2.

5.2 Credit-Scoring for Micro Lending

A precise estimation of a user’s creditworthiness is essential for the successful longterm operation of micro lending businesses. User’s creditworthiness is commonly expressed using individual credit scores based on a formal process for determining how likely applicants are to default with their repayments [19]. A high credit score indicates the user’s capability to fulfill all obligations of a lending contract, whereas a low credit score indicates the opposite. Issuing loans to customers who might fail to pay back their loan is a potential business risk, i.e., a credit default risk. In order to minimize the credit default risk of Everex’s micro lending services, a thorough financial analysis of the potential borrower is conducted.

The financial analysis is based on three main data feeds provided by the user, i.e., personal data, social media data and the user’s transaction history. The first two data feeds are accessed using the borrower’s mobile phone while the latter is available on the blockchain. Personal data covers information such as SMS data, call logs, contact data, etc. Similarly, social media data is gathered by requesting access to the users social media accounts, thereby extracting communication histories, shared content and social status information. Furthermore, meta information and contents of pictures are analyzed to derive additional data feeds. Finally, geo-location based data might also be used as input for the credit-scoring algorithm. Combining multiple data feeds for further processing yields additional information, e.g., when the *Pay-with-a-Selfie* payment system [11] is used, where pictures are taken with mobile phones used to embed all business transaction related information, the credit scoring algorithm extracts location

information, picture meta data, contact information and a confirmation of a positive payment statement. In addition to the data feeds collected from the borrower, lenders may also maintain internal databases with credit-related information. Users who repeatedly failed to fulfill their obligations are blacklisted, whereas other users might be on a specific white list resulting in better loan conditions for them. Another factor of the scoring system is the available (positive) credit- and payment history of the borrower. In case the potential lender is a reliable and frequent user of the Everex eco-system, his/her credit score improves resulting in better loan conditions. Moreover, existing debt burdens of the lender are also taken into account, e.g., borrowers do not issue additional loans if the user is already involved in several running lending contracts. Finally, Everex's EVX tokens are also available to improve users credit scores. A detailed outline of the EVX token value proposition and its influence on the credit score is presented in Section 5.3.

The information gathered from the sources listed above are processed in an automated manner resulting in a numerical credit score. Based on this credit score and the lender's credit policies, a loan is either issued, or denied.

5.3 EVX-Token Value Proposition

The previous section's focus on the business architecture and business processes of the micro lending running case. The Everex EVX token is publicly tradable and a key component of the system that enables the micro lending service. EVX serves two main objectives: First, the token is the fuel of an internal reward system of the Everex eco-system. Second, it is part of the governance component of the capital-transfer system.

Each Everex wallet is initially equipped with a predefined amount of EVX and cannot be used without a minimum EVX balance. As part of our internal reward system, EVX tokens are used to improve user-credit score. The more EVX a user posses, the better the offered loan conditions since the user owns a larger stake in the Everex system. Users can earn, or buy additional EVX tokens, thereby enhancing their creditworthiness. Borrowers who make use of the micro lending service are rewarded with additional EVX token if they pay back the Cryptocash loan under the specified constraints of the lending contract. In addition, users can vouch for the borrower with their own EVX tokens. As a result, the borrower receives improved lending conditions. In case the borrower pays back the loan as specified, both the borrower and the vouching user are rewarded with EVX tokens. Finally, lenders can earn EVX tokens by providing loans as a reward for their risk in addition to the payed interest rates. In case that any of the involved entities fails to fulfill his/her duties of the lending agreement, the provided EVX tokens are confiscated by the smart contract. Note that a user's credit score is calculated based on different inputs as described in Section 5.2 and available EVX tokens are only one part of the equation. Furthermore, users can sell or donate their EVX tokens to other users or Everex directly, thereby improving the receiving user's credit score and losing their own. Since

all account balances are transparent on the blockchain, each user’s credit score is publicly available online.

The second objective of the token is to implement a governing voting system. EVX token holders vote on how much of the Everex funds are allocated for token buy back on a regular base. As mentioned in Section 2.1, system stakeholders can also vote on requests to update Cryptocash token contracts. Each user’s voting depends on the owned EVX token proportionally to the available 22.7 million EVX tokens.

6 Evaluation

Everex conducts a case-study of its remittance system with over 100 Myanmar migrant workers living in Thailand. Over a period of 46 days, more than 1,100,000 Thai Baht, about 31,000\$, are transferred using Everex wallets and Cryptocash tokens via the Ethereum blockchain. The Myanmar migrant workers in Thailand elect a community leader who represents a group of workers and collects the transfer money. In cooperation with Everex, the community leader converts collected Thai Baht into the Cryptocash equivalent THBEX and transfers it instantly over the blockchain to a licensed currency exchange in Myanmar. In Myanmar, the Cryptocash THBEX is converted to the countries local currency Kyat and provided to the receiving families of the migrant workers. In order to transfer the Thai Baht-based Cryptocash back to Everex, the Myanmar financial institution uses the available funds to import goods and services from Thailand using Everex as a middle man. Even though an elected community leader handles the money transfer for a group of migrant workers, it is not required to have such a middle man. Instead, each of the migrant workers can directly exchange his/her Thai Baht to THBEX at an exchange and send it to Myanmar. Furthermore, the unidirectional payback and transfer of THBEX balances between the Myanmar exchange and Everex is not necessarily required due to a decentralized and federated network of licensed financial institutions and cash custodians that will be available with the official launch of the Everex eco-system.

Our case-study covers 224 transactions with a total transfer volume of 1,110,148 THBEX and an average transaction size of 4,956 THBEX. The large average transaction size is caused by the accumulated capital transfer of multiple migrant workers through the community leader. Therefore, we expect smaller sizes when used by individuals instead of groups. As illustrated in Figure 12, transaction cluster appear on a weekly, or bi-weekly basis, representing the salary cycles of the migrant workers. With each payment cycle of the case-study, the number of transactions as well as the THBEX transfer volume increases, depicting a user adoption to the new remittance tool. On average, the users save ca. 7% in remittance costs and currency-exchange rates when using the Everex capital transfer system. Moreover, an average transaction takes less than a minute, while existing remittance and transfer systems suffer from long lines and waiting times. Even though the recipients use Myanmar money-changers to switch from Cryptocash

back to physical cash, no centralized entity performs the actual remittance. As a result, remittance cost and transfer time decrease, since the transmission process is automated with programmable smart contracts on Ethereum.

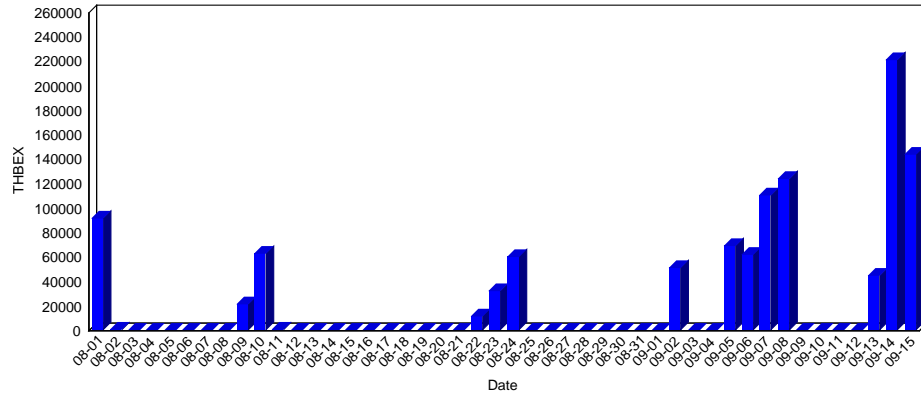

Fig. 12: THBEX transfer volume during the 46 days of the case-study.

7 Conclusion

This whitepaper presents the blockchain-based Everex capital transfer system that aims to enable and ease the financial inclusion of two billion unbanked, or underbanked adults around the world. To do so, Everex proposes the novel concept of Cryptocash, a cryptocurrency, where each unit has its value pegged to, and a name based on, the fiat currency it represents. Users convert local fiat currencies to Cryptocash using a currency exchange and transfer the coins to their Everex wallet. Cryptocash balances are provably underwritten by actual balances held in accounts of licensed financial institutions. The Everex system provides its users access to financial services using Cryptocash, without the volatility issues of existing, non-stablecoin cryptocurrencies. Combining traditional financial services with novel blockchain technology and smart contracts enables users currently excluded from the financial system to access services such as payment, remittance, currency exchange and micro lending. As a result, Everex renders existing capital transfer systems obsolete that are expensive, suffer from long lines, exchange rate losses, counter-party risks, bureaucracy and extensive paperwork.

We demonstrate the capabilities of the blockchain-based capital transfer eco-system in a running case for micro lending, thereby outlining the general Cryptocash-based lending process and detailing the lifecycle of a micro lending contract. Based on the running case, we identify the requirements and criteria

that a global blockchain-based capital transfer system must satisfy. With respect to functional requirements, Everex plans to develop a cross-border remittance, payment- and micro lending system. The resulting platform does not only provide unbanked and underbanked users with access to financial services, but also reduces costs and execution times for those services.

Subsequently, we derive the service-oriented architecture of the Everex capital transfer system based on the identified requirements and goals. We present the system architecture using technology-agnostic UML-component-diagrams that detail the system’s main components and communication interfaces. The Everex system is composed of four main components, each representing one of the financial services provided by the system and furthermore mapping to the identified functional requirements. Components enabling remittance-, payment- and currency-exchange services already exist. Thus, special focus is given to the integration of the micro-lending component implementing the chosen running-case.

The business process of the micro lending running case is outlined using the BPMN representation. We focus on the integral stages of a micro lending process, starting with the request of a loan by a user, followed by the credit scoring calculations, lending contract negotiations as well as loan distribution and payback. We recognize the importance of credit scoring for each micro lending process. Therefore, we provide an overview on the algorithm to estimate the creditworthiness of our users, based on personal data, financial data and social media data. Personal data is extracted from the user’s mobile phone in combination with social media data from social networks. Financial data refers to the publicly and transparently available transaction history of the user on the Ethereum blockchain. Finally, we present the EVX token value proposition. The EVX token is a tradable reward-based credit scoring unit that is used to enhance user’s credit scoring. Moreover, users can vouch with their own EVX for other users, thereby ensuring better credit ratings for them. Adhering to the specified lending contract constraints is rewarded with additional EVX tokens. In addition, EVX token entitle users to participate in governing voting processes of the Everex community.

Next, we present a case-study of the Everex cross-border remittance system with over 100 Myanmar migrant workers living in Thailand, using Cryptocash to transfer a total amount of \$31,000, thereby proving the feasibility of the system. Transaction and remittance costs as well as the transfer time decrease and ease the access to basic financial services for the users. On average, the users save about 7% in remittance costs and currency-exchange rates when using the Everex capital transfer system.

Future releases of the Everex financial eco-system provide functionalities for secure lending as well as crow-lending. In addition, we acknowledge the necessity of incorporating financial services that adhere to the rules of Islamic banking, due to the large share of Muslims among the millions of migrant workers and refugees. Moreover, we aim to gradually introduce Cryptocash and Everex to further countries, thereby increasing the coverage of our services. Furthermore, we plan to integrate Agrello’s self-aware and agent-assisted smart contracts [40]

into the Everex micro lending contract framework. Finally, we aim to incorporate machine learning as well artificial intelligence techniques into the credit scoring algorithm, thereby achieving more accurate results and higher degrees of automation that lowers the cost of providing the micro lending service.

References

1. Amin, S., Rai, A.S., Topa, G.: Does Microcredit Reach the Poor and Vulnerable? Evidence from Northern Bangladesh. *Journal of Development Economics* 70(1), 59–82 (2003)
2. Booch, G., Jacobson, I., Rumbaugh, J., et al.: The Unified Modeling Language. *Unix Review* 14(13), 5 (1996)
3. Bruton, G.D., Khavul, S., Chavez, H.: Microlending in Emerging Economies: Building a New Line of Inquiry From the Ground Up. *Journal of International Business Studies* 42(5), 718–739 (2011)
4. Business Process Model: Notation (BPMN) Version 2.0. OMG Specification, Object Management Group (2011), <http://www.bpmn.org>.
5. Bussmann, O.: The Future of Finance: FinTech, Tech Disruption, and Orchestrating Innovation. In: *Equity Markets in Transition*, pp. 473–486. Springer (2017)
6. Chen, S., Ravallion, M.: How Have the World’s Poorest Fared Since the Early 1980s? *The World Bank Research Observer* 19(2), 141–169 (2004)
7. Christidis, K., Devetsikiotis, M.: Blockchains and Smart Contracts for the Internet of Things. *IEEE Access* 4, 2292–2303 (2016)
8. Cull, R., Demirgüç-Kunt, A., Morduch, J.: Microfinance Meets the Market. In: *Moving Beyond Storytelling: Emerging Research in Microfinance*, pp. 1–30. Emerald Group Publishing Limited (2009)
9. Dai, P., Mahi, N., Earls, J., Norta, A.: Smart-Contract Value-Transfer Protocols on a Distributed Mobile Application Platform. URL: <https://qtum.org/uploads/files/cf6d69348ca50dd985b60425ccf282f3.pdf> (2017), (Accessed May 18, 2017)
10. Daly, H.E.: Population Migration and Globalization. *World Watch* pp. 41–44 (2004), URL: <http://www.worldwatch.org/system/files/EP175I.pdf> (Accessed May 11, 2017)
11. Damiani, E., Hougbo, P.J., Asal, R., Cimato, S., Frati, F., Honsou, J.T., Shehada, D., Yeun, C.Y.: Pay-with-a-Selfie, a Human-Centred Digital Payment System. arXiv preprint arXiv:1706.07187 (2017)
12. Davis, A.M.: *Software Requirements: Objects, Functions, and States*. Prentice-Hall, Inc. (1993)
13. Demirguc-Kunt, A., Klapper, L., Singer, D., Van Oudheusden, P.: *The Global Findex Database 2014*. URL: <http://documents.worldbank.org/curated/en/187761468179367706/pdf/WPS7255.pdf> (2015), (Accessed May 02, 2017)
14. Emmadi, N., Narumanchi, H.: Reinforcing Immutability of Permissioned Blockchains with Keyless Signatures’ Infrastructure. In: *Proceedings of the 18th International Conference on Distributed Computing and Networking*. p. 46. ACM (2017)
15. Erl, T.: *Service-Oriented Architecture: Concepts, Technology, and Design*. Pearson Education India (2005)
16. Everett, C.R.: Origins and Development of Credit-Based Crowdfunding. URL: https://papers.ssrn.com/sol3/papers.cfm?abstract_id=2442897 (2014), (Accessed July 04, 2017)

17. Faggart, E.: The Economics of Stablecoins. URL: <http://bitcoinist.com/stablecoins-economics/> (2016), (Accessed May 09, 2017)
18. Gill, M., Taylor, G.: Preventing Money Laundering or Obstructing Business? Financial Companies' Perspectives on Know Your Customer Procedures. *British Journal of Criminology* 44(4), 582–594 (2004)
19. Hand, D.J., Henley, W.E.: Statistical Classification Methods in Consumer Credit Scoring: A Review. *Journal of the Royal Statistical Society: Series A (Statistics in Society)* 160(3), 523–541 (1997)
20. Hartley, S.E.: Kiva.org: Crowd-Sourced Microfinance and Cooperation in Group Lending (2010)
21. Hughes, N., Lonie, S.: M-PESA: Mobile Money for the Unbanked Turning Cell-phones Into 24-hour Tellers in Kenya. *Innovations* 2(1-2), 63–81 (2007)
22. IEEE Computer Society. Software Engineering Technology Committee and Institute of Electrical and Electronics Engineers: IEEE Recommended Practice for Software Requirements Specifications. IEEE Std, Institute of Electrical and Electronics Engineers (1994)
23. Jack, W., Suri, T.: Mobile Money: The Economics of M-PESA. Tech. rep., National Bureau of Economic Research (2011)
24. Khandker, S.R., et al.: Fighting Poverty with Microcredit: Experience in Bangladesh. Oxford University Press (1998)
25. Kutvonen, L., Norta, A., Ruohomaa, S.: Inter-Enterprise Business Transaction Management in Open Service Ecosystems. In: Enterprise Distributed Object Computing Conference (EDOC), 2012 IEEE 16th International. pp. 31–40. IEEE (2012)
26. Leiding, B., Cap, C.H., Mundt, T., Rashidibajgan, S.: Authcoin: Validation and Authentication in Decentralized Networks. In: The 10th Mediterranean Conference on Information Systems - MCIS 2016. Cyprus, CY (September 2016)
27. Leiding, B., Memarmoshrefi, P., Hogrefe, D.: Self-Managed and Blockchain-Based Vehicular Ad-Hoc Networks. In: Proceedings of the 2016 ACM International Joint Conference on Pervasive and Ubiquitous Computing: Adjunct. pp. 137–140. ACM (2016)
28. Lundkvist, C., Heck, R., Torstensson, J., Mitton, Z., Sena, M.: uPort: A Platform for Self-Sovereign Identity. URL: https://whitepaper.uport.me/uPort_whitepaper_DRAFT20170221.pdf (2017), (Accessed May 02, 2017)
29. Majois, C., Van Damme, S.: Peer to Peer Microfinance: The Case of Zidisha.org. Master's thesis, Louvain School Of Management, France (2013)
30. Marshall, J.: Agent-Based Modelling of Emotional Goals in Digital Media Design Projects. *International Journal of People-Oriented Programming (IJPOP)* 3(1), 44–59 (2014)
31. Mussa, M.: Factors Driving Global Economic Integration. *Global Economic Integration: Opportunities and Challenges* pp. 9–55 (2000)
32. Nakamoto, S.: Bitcoin: A Peer-to-Peer Electronic Cash System. URL: <https://bitcoin.org/bitcoin.pdf> (2008), (Accessed May 02, 2017)
33. Narendra, N.C., Norta, A., Mahunnah, M., Ma, L., Maggi, F.M.: Sound Conflict Management and Resolution for Virtual-Enterprise Collaborations. *Service Oriented Computing and Applications* 10(3), 233–251 (2016)
34. Navajas, S., Schreiner, M., Meyer, R.L., Gonzalez-Vega, C., Rodriguez-Meza, J.: Microcredit and the Poorest of the Poor: Theory and Evidence from Bolivia. *World development* 28(2), 333–346 (2000)
35. Nguyen, Q.K.: Blockchain - A Financial Technology for Future Sustainable Development. In: Green Technology and Sustainable Development (GTSD), International Conference on. pp. 51–54. IEEE (2016)

36. Norta, A.: Creation of Smart-Contracting Collaborations for Decentralized Autonomous Organizations. In: International Conference on Business Informatics Research. pp. 3–17. Springer (2015)
37. Norta, A.: Establishing Distributed Governance Infrastructures for Enacting Cross-Organization Collaborations. In: International Conference on Service-Oriented Computing. pp. 24–35. Springer (2015)
38. Norta, A., Grefen, P., Narendra, N.C.: A Reference Architecture for Managing Dynamic Inter-Organizational Business Processes. *Data & Knowledge Engineering* 91, 52–89 (2014)
39. Norta, A., Othman, A.B., Taveter, K.: Conflict-Resolution Lifecycles for Governed Decentralized Autonomous Organization Collaboration. In: Proceedings of the 2015 2nd International Conference on Electronic Governance and Open Society: Challenges in Eurasia. pp. 244–257. ACM (2015)
40. Norta, A., Vedeshin, A., Rand, H., Tobies, S., Rull, A., Poola, M., Rull, T.: Self-Aware Agent-Supported Contract Management on Blockchains for Legal Accountability. URL: http://whitepaper.agrello.org/Agrello_Self-Aware_Whitepaper.pdf (2017), (Accessed July 04, 2017)
41. Ouaddah, A., Elkalam, A.A., Ouahman, A.A.: Towards a Novel Privacy-Preserving Access Control Model Based on Blockchain Technology in IoT. In: Europe and MENA Cooperation Advances in Information and Communication Technologies, pp. 523–533. Springer (2017)
42. Perrey, R., Lycett, M.: Service-Oriented Architecture. In: Applications and the Internet Workshops, 2003. Proceedings. 2003 Symposium on. pp. 116–119. IEEE (2003)
43. Rahman, A.: Micro-Credit Initiatives for Equitable and Sustainable Development: Who Pays? *World Development* 27(1), 67–82 (1999)
44. Rahman, A., Milgram, B.L.: Women and Microcredit in Rural Bangladesh: An Anthropological Study of Grameen Bank Lending. *Anthropologica* 43(2), 281 (2001)
45. Roy, A.: Microfinance. John Wiley and Sons, Ltd (2015), <http://dx.doi.org/10.1002/9781118785317.weom060143>
46. Sengupta, R., Aubuchon, C.P., et al.: The Microfinance Revolution: An Overview. *Review-Federal Reserve Bank of Saint Louis* 90(1), 9 (2008)
47. Specification, O.A.: OMG Unified Modeling Language (OMG UML), Superstructure, V2.1.2. Object Management Group (2007)
48. Sterling, L., Taveter, K.: *The Art of Agent-Oriented Modeling*. MIT Press (2009)
49. The World Bank: Universal Financial Access is Vital to Reducing Poverty, Innovation Key to Overcoming the Enormous Challenge, Says President Jim Yong Kim. URL: <http://www.worldbank.org/en/news/press-release/2013/10/11/universal-financial-access-vital-reducing-poverty-innovation-jim-yong-kim> (2013), (Accessed May 11, 2017)
50. The World Bank: Remittance Prices Worldwide. URL: https://remittanceprices.worldbank.org/sites/default/files/rpw_report_march_2017.pdf (2017), (Accessed May 11, 2017)
51. Weber, I., Xu, X., Riveret, R., Governatori, G., Ponomarev, A., Mendling, J.: Untrusted Business Process Monitoring and Execution Using Blockchain. In: International Conference on Business Process Management. pp. 329–347. Springer (2016)
52. Wolf, M.: Shaping Globalization. *Finance and Development* 51(3), 22–25 (2014)
53. Wood, G.: Ethereum: A Secure Decentralized Generalised Transaction Ledger. URL: <http://gavwood.com/paper.pdf> (2014), (Accessed May 02, 2017)

54. World Bank Group: Migration and Development. URL: <http://pubdocs.worldbank.org/en/468881473870347506/Migration-and-Development-Report-Sept2016.pdf#page=11&zoom=auto,-177,554> (2016), (Accessed May 15, 2017)
55. Zaman, H.: Assessing the Poverty and Vulnerability Impact of Micro-Credit in Bangladesh: A Case Study of BRAC (1999)