



# Digital inheritance service

## Token Sale

## Disclaimer

*Disclaimer: this document, further known as “White Paper”, establishes and defines the principles on which the DigiPulse project will operate regarding the business model and the technical solution. The information in the White Paper is subject to change - all changes can be found under section “Revisions to version”. For legal matters please refer to “Terms and Conditions” that are located on our website [www.DigiPulse.io](http://www.DigiPulse.io)*

## Overview

The aim of this document is to give an in-depth look and explanation of the:

- Proposed service;
- Business model and the investment opportunity;
- Token sale conditions, token distribution, token circulation and fund usage;
- Project’s roadmap and the team behind it.

## Abstract

DigiPulse is creating a service for users of cryptocurrencies, that allows to encrypt and automatically pass on sensitive information and data by utilising the blockchain technology.

With the increasing usage and value of cryptocurrencies, the issue of securing and passing your assets on to inheritors is also gaining importance. Most online services do not consider this as a legitimate problem for their users, since the age of full digitalization is still at its early stage.

The goal of the proposed project is to ensure that digital assets stored in crypto wallets are passed on/made available to the rightful inheritors, in case of the own-

er’s death.

Our service will have a B2C (Business to Customer) business model. It will be subscription based, where each asset release timestamp update is paid in DGPT tokens:

**The solution – DigiPulse will provide the interface to operate with a smart contract that will hold the hash of the encryption key for the data that is encrypted and stored on our blockchain.**

We are launching a token sale for DGPT – the DigiPulse token. The proceeds from the token sale will be used to set up the service. The DGPT in turn will be used as the means of payment to use the service.

# Contents

Creation of the project.....	4
The Problem .....	4
The Opportunity.....	4
Business model.....	5
Storage provider rewards.....	5
Profit sharing .....	5
Token circulation.....	5
Service description.....	6
Security.....	8
Technology.....	10
Asset transfer .....	10
Business potential .....	10
State of the project .....	10
Token holders.....	11
Token sale details.....	11
Token distribution during token sale.....	12
Bounty distribution .....	12
Raised fund usage.....	13
Distribution.....	13
Escrow .....	13
Fund storage .....	13
Roadmap .....	14
The Company.....	15
The background of DigiPulse.....	15
Team.....	16

# Creation of the project

DigiPulse was launched in Riga, Latvia in 2016. The concept came from the Co-founder Dmitry Dementyev-Dedelis who has gained in-depth fundraising, psychological and technical experience from his previous experience working as the CTO for the company Funderful. The Idea originated from working extensive hours for a three year period, thus compromising health to the point, where the need for such a service arose. The idea gained an additional spin when presented to the Co-founder Normunds Kvilis, who has a banking background and added the cryptocurrency aspect to

the initial idea of storing memorabilia and valuables.

The idea came from the fact that we as humans are vulnerable to mortality and if anyone of us were to pass away, it wasn't quite sure how the rightful inheritors would gain access to everything stored online. Of course, not anything we accumulate can be considered as "valuable", but when it comes to assets that contain monetary value, it seems careless not to pass such things on. Hence the focus on cryptocurrencies.

## The Problem

With the creation of Blockchain technology in 2009, people all over the world are starting to use cryptocurrencies as an alternative form of payments and investments. But this form of currency has a flaw – if the user can't access the digital wallet where the currency is stored (because of death or loss of memory), then these assets will remain dormant and lost to anyone forever. This in turn can lead to huge losses if a single person stores all of his assets in crypto wallets.

Currently no other solution exists of making cryptocurrency assets inheritable (while still using them). Regarding solutions like password boxes, the master password still needs to be handed out to an inheritor

(that could be forgotten) and the information needs to be made known to the inheritor in the first place. The passing on of digital keys can also be done with the help of physical storage means e.g. a "paper key" or USB stick, but they are still vulnerable to theft.

Additionally, centralisation plays a huge role in the asset storage process. From the crypto currency holders point of view, it doesn't seem safe or viable to hand their valuable information on to a centralised service, that would be vulnerable to internal human resource misconduct - thus the usage of blockchain plays a huge role.

## The Opportunity

Blockchain and the decentralisation aspect of it is the perfect setting into which an asset encryption and distribution storage service is set up. This allows to encrypt, split and store information on multiple devices across the world thus ensuring that we, as a service provider, do not have access to the information the user wishes to encrypt (a completely decentralized service) and the threat of internal risks which come from human resources is mitigated completely.

The Ethereum smart contract is a powerful tool if applied correctly. In our case we are using this technology to create a new service for those who wish to keep

their assets safe, make them inheritable and remain anonymous (if they wish to) in the process.

In addition, we have created a solution that deals with the inheritance access send-out in an automated way, by utilising the "activity tracking" of the user through multiple web based integrations or the smart contract itself. Our solution requires only a one time set-up of the service, if no additional files/information need to be added to the inheritable "vault" and the DGPT, which allows the user to prolong the *asset release time-stamp* for the smart contract.

# Business model

Our business model focuses on two types of users: those who wish to remain completely anonymous and those for whom this is not an issue. The difference between these two types will determine the way the asset release timestamp resets.

DigiPulse will use a subscription model per single transaction. The way the user pays for the service will be with DigiPulse tokens (DGPT) that will be available during the token sale and afterwards, listed on cryp-

tocurrency exchanges. The payment in DGPT is only made when the “send-out switch” for the smart contract is reset.

We are also granting the community the involvement to our project by letting people become storage space providers to maintain our blockchain. These participants will receive a portion of the DGPT that will be paid to reset the asset release timestamp on entries in the smart contract.

*Our service will have a B2C (Business to Customer) business model. It will be subscription based, where each asset release timestamp update is paid in DGPT tokens*

## Storage provider rewards

Blockchain storage space providers - will receive **50% of the DGPT** that will be accumulated by DigiPulse as a means of payment for the service from the users;

$$x = \left\{ \frac{A1}{100} * 50 \right\} = 50\% \text{ of accumulated}$$

$$\text{Profit} = (\text{Accumulated} / 100 * 50) / 100 * 75$$

$$A = \left\{ \frac{x}{100} * 75 \right\} = 75\% \text{ of the } 50\%$$

## Profit sharing

DigiPulse profit sharing will be only available **when the legal framework is set up**. The DGPT is a standard “usage” token - it only serves as a means of payment to use the DigiPulse service. These precautions are being made in order to protect the investors and their assets. The estimated time for the development and finalization of this feature is set at the end of Q4 2017.

**“10k+” DGPT token holders** - the token holders who have amassed more than 10'000 DGPT will be eligible to transfer their existing tokens to **DGPS<sup>1</sup>**, that will grant 75% of the 50% that will be accumulated by DigiPulse as a means of payment for the service from the users **in the form of ETH**, based on the real time DGPT/ETH exchange rate (distributed on a pro-rata basis).

## Token circulation

From all the available DGPT tokens, 25% will remain on the DigiPulse smart contract serving as the reserve for rewarding storage providers in cases when no smart contracts have been set up and no revenue from asset release timestamp resets is made. The minimum payout made during each cycle is 1'000 EUR worth of

DGPT, thus incentivising storage providers to support the blockchain. Upon reaching the revenue of more than 1'000 EUR worth of DGPT, 20% of it (DGPT) are allocated to refill the shares of the company on the smart contract and the rest is being distributed to the storage providers and future DGPS holders.

$$\text{payout} = \max(\text{revenue} - \min\left(\frac{\text{total supply}}{4} - \text{company tokens}\right), \frac{\max(\text{revenue}, 1000)}{5}), 1000)$$

<sup>1</sup> DGPS - this token **will not be traded on exchanges**. Its sole purpose is to act as means for the smart contract to identify those who are eligible for profit sharing.

All tokens received in the DigiPulse smart contract above 25% from the total token supply are put up on the EtherDelta exchange for sale, so the Ethereum received from token sales can be used for the necessary gas expense accommodation for the operations with the smart contract. 50% from the received Ethereum are immediately reserved for future token holders who own DGPS and 50 % are kept for operational costs.

The excess Ethereum on the smart contract at the end of the quarter will be allocated for future profit share,

thus no Ethereum is frozen on the DigiPulse smart contract for a period longer than 3 months.

This way tokens are always in circulation and by reducing the available amount on the market their value supposedly will increase.

A price controlling mechanism for asset release timestamp resets will be implemented - the token costs for operations with the smart contract will equal a fixed amount of EUR.

## Service description

DigiPulse is a subscription based SaaS platform that allows to store and encrypt information on the DigiPulse blockchain and make it inheritable (only accessible to the specified recipients).

The user has to sign up for the service by **at least** providing the public wallet address and the contact email. The information the user wishes to pass on will be encrypted with the help of an AES-256 high strength security implementation and stored on DigiPulse blockchain. The user will use the DigiPulse platform to put the information on the blockchain. Any type of files

can be stored and can take up to 1 GB storage space. DigiPulse will utilise Ethereum smart contracts that act as the mechanism for the information hand out to the inheritors. Smart contract will have the “inactivity period” and inheritor access information embedded into them. In addition, a smart contract will hold DGPT that allows the resetting of the “inactivity period” that triggers the data send out to take place. The resetting is the process that requires the payment from the user. The “inactivity period” is a time frame that is set up by the user.

*In the case where the user wants to use the service completely anonymously, there will be three options that will reset the “inactivity period”:*

1. Manual interaction with the information storage on DigiPulse;
2. Account balance difference check-ups conducted by DigiPulse, based on the “inactivity period” time frame;
3. Usage of the DigiPulse computer/smartphone application (this still lets to use the service anonymously as the only login option is the “wallet address”).

DigiPulse will offer **another option** for “inactivity period” resetting that will utilise integrations from other services that the user has already subscribed to (e.g. Facebook/Twitter activity, Gmail (automated emails),

DigiPulse smartphone application, etc.). The only precondition for DigiPulse to be able to track the activity of the user is that the service has an open API that DigiPulse can utilise and integrate with.

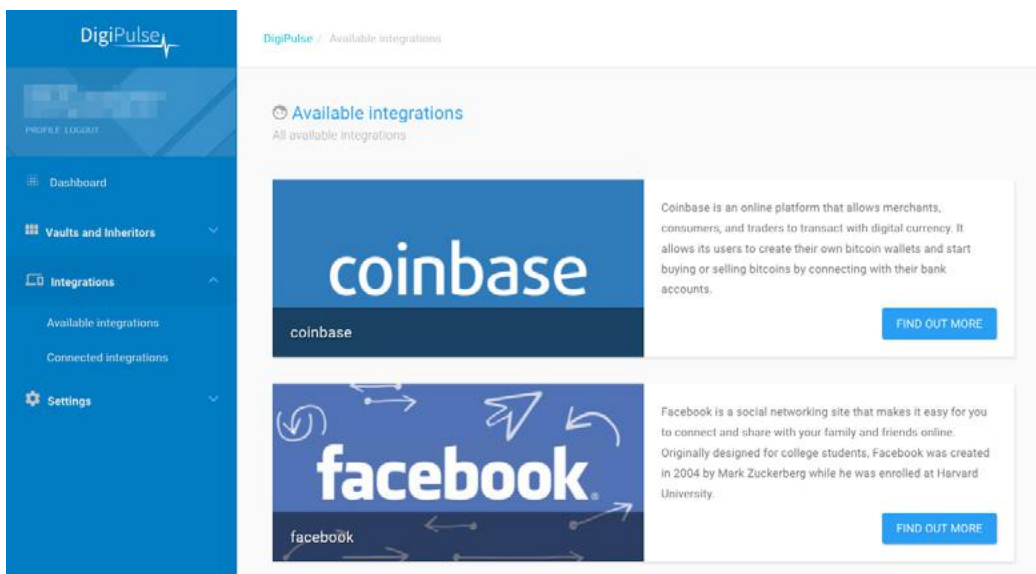

Alternatively, the contract can be setup to send the information on it's own if no reset has been received within a user-settable timeframe.

An inheritor is assigned for every “vault” the user creates. In the scenario where the user wishes to use DigiPulse anonymously, the selected inheritor can access

it after the original user’s smart contract has not reset the “inactivity period”. In this case, the inheritor will be informed using the information that will be stored on the smart contract by the original asset holder. The inheritor will receive a link to the smart contract to complete the identity verification in order to gain access to the vault:

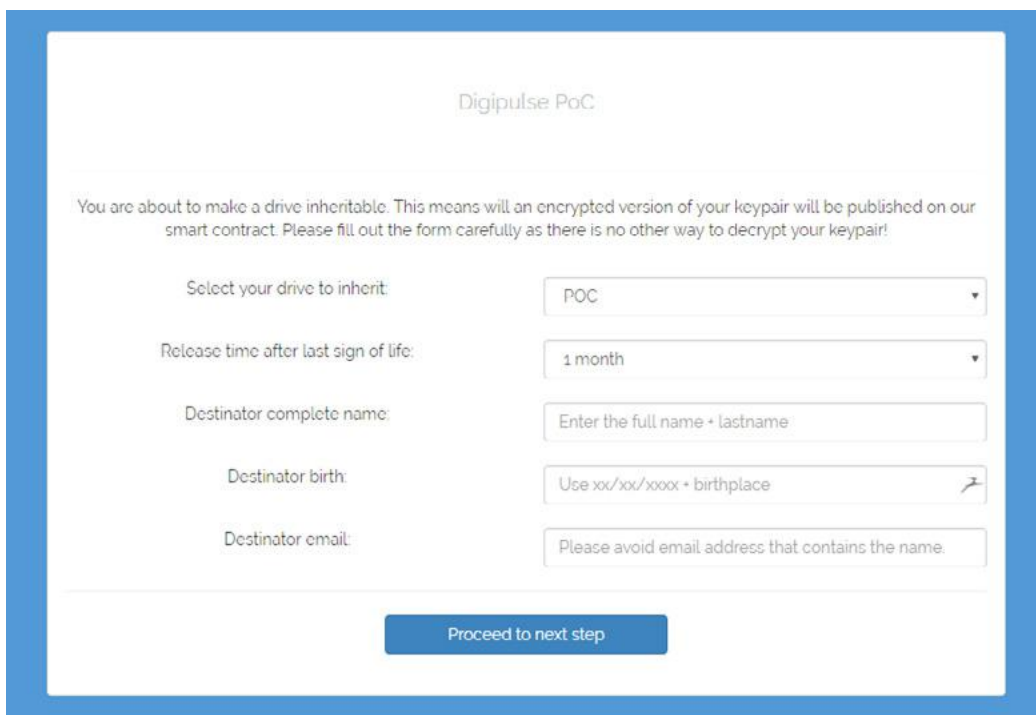

“Smart Vaults” are stored on Ethereum blockchain, thus they are completely controlled by the person, who set them up. DigiPulse will only provide the user interface

to simplify the interaction with the “smart vault” and perform activity checks if opted-in by the vault creator.

# Security

The database that will be accessible with the help of the DigiPulse platform is **completely decentralized** and utilises data storing on multiple storage providers, thus eliminating the threat of a single point of access to any user's data.

Integrations require a high level of security - the aim is to set up PCI DSS level of security and get the appropriate certifications in place. PCI DSS is a commonly used certification type by banks and other financial industries which require a strong auditing and PII (personally identifiable information) protection.

The DigiPulse service does not know and does not intend to know about the contents of the vault. All files can additionally be encrypted by the users, encouraging the user to keep a security passphrase separately from the DigiPulse service. This passphrase can be distributed physically, for example in the last will.

When storing your credentials on the blockchain, we need to assume security first.

DigiPulse will use the AES-256 algorithm to encode the credentials publicly on the blockchain. AES became effective as a federal government standard on May 26, 2002, after approval by the Secretary of Commerce. AES is included in the ISO/IEC 18033-3 standard. AES is available in many different encryption packages, and is the first (and only) publicly accessible cipher approved by the National Security Agency (NSA) for top secret information when used in an NSA approved cryptographic module.

While AES encryption exists in multiple forms, DigiPulse will use AES-256-CBC, also known as Cipher Block Chaining (CBC). In CBC mode, each block of plaintext is XORed<sup>1</sup> with the previous ciphertext block before being encrypted. This way, each ciphertext block depends on all plaintext blocks processed up to that point. To make each message unique, an initialization vector<sup>2</sup> must be used in the first block.

Structure of AES-256-CBC methods:

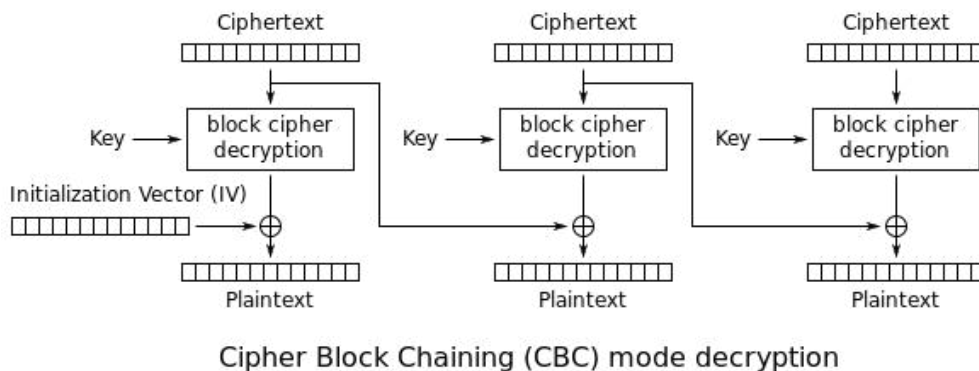
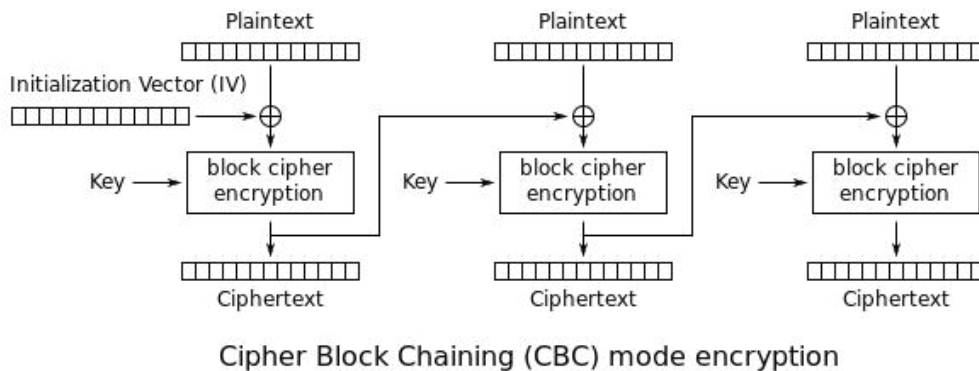

1 <https://en.wikipedia.org/wiki/XOR>

2 [https://en.wikipedia.org/wiki/Initialization\\_vector](https://en.wikipedia.org/wiki/Initialization_vector)



If the first block has index 1, the mathematical formula for CBC encryption is

$$C_i = E_k(P_i \oplus C_{i-1}),$$

$$C_0 = IV.$$

If the first block has index 1, the mathematical formula for CBC decryption is

$$P_i = D_k(C_i \oplus C_{i-1}),$$

$$C_0 = IV.$$

Decrypting with the incorrect IV causes the first block of plaintext to be corrupt but subsequent plaintext blocks will be correct. This is because each block is XORed with the ciphertext of the previous block, not the plaintext, so one does not need to decrypt the previous block before using it as the IV for the decryption of the current one. This means that a plaintext block can be recovered from two adjacent blocks of ciphertext. As a consequence, decryption can be parallelized.

OpenSSL AES-256-CBC uses what's known as *salt*, that DigiPulse names the *Sharing key*, in combination with the password to generate two values: the IV and the actual encryption key. The IV is derived from the password and the input data present in the file header, and calculated on the fly. The OpenSSL developers preferred to derive the IV from the password, just like the key (i.e. they produce from the password a long sequence, which they split in two, one half being the encryption key, the other half being the IV).

The IV and the salt must be uniformly random as possible to prevent possible attacks on the publicly stored hashes. DigiPulse ensures this uniform random by applying the OpenSSL standards of using the the IV derived from the password, and the sharing key in randomly generated at each contract creation event.

One of many options on how to make the drive inheritable consists of publicly storing this Sharing key in a separate contract. By using high security strength encryption processes, DigiPulse can create a sharing key derived from the user's input. It would still need data that only the beneficiary knows to decrypt this publicly stored hash value, that in terms hold the sharing key to unlock the storage drive with the user data inside.

With the option to publish the sharing key encrypted on a separate contract, the key can be derived from up to 7 different parameters, fully selectable by the user.

Flowchart on how we will create a public hash to decrypt the sharing key:

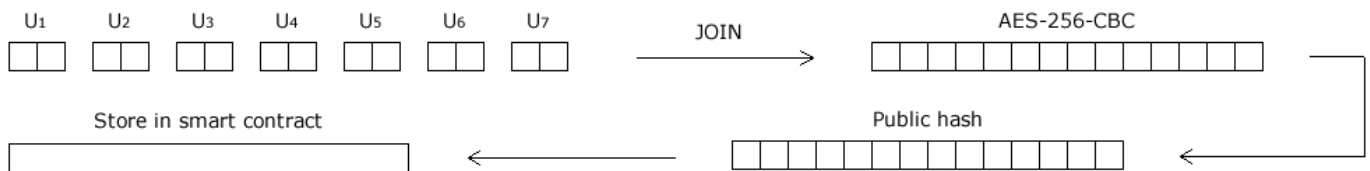

Note that his function is only applicable if the contractor wishes to hide the existence of the drive from his relatives until the death trigger has been set. Security wise, this is considered the least stable solution.

## Technology

The technology for the DigiPulse Blockchain will be based upon the open source of Storj<sup>1</sup>. DigiPulse will create a framework around their already well built, tested and very trusted protocol, thus ensuring that the best practices of the community are put to use. DigiPulse will ensure cooperation with the community regarding the network server software under GNU<sup>2</sup> General Public License.

“Smart Vaults” are stored on the Ethereum blockchain via an ERC20 compliant smart contract. The DigiPulse service has wallet addresses stored of the appropriate entries on the smart contract, so the activity period can be tracked more precisely and improved even further by connecting API integrations for activity track-

ing, or by downloading mobile apps that perform this task in the background. The upside of this approach is that the release is not being activated solely on the activity of the vault creators wallet, but instead is accumulated from different channels, eventually incorporating machine learning aspects to avoid false positive activity pings and removing the necessity to perform manual resets. The goal of the service is to become fully autonomous without the necessity for the user to spend any time whatsoever on thinking, whether the asset release timestamp has been reset. The goal of the service is to provide the same peace of mind as a physical last will. An email with an inquiry about the whereabouts of the user is sent as the final fail-safe before the asset release is made.

The email address of the vault creator is necessary for following scenarios - notification about the balance of the DGPT running low, periodical check on whether the email provided for the inheritor is still the same and

fail-safe before the asset release.

## Asset transfer

DigiPulse allows to have the verification with and without the user ID - users who will choose the former will be able to use third party services as the “activity tracking” channels. In the case of the latter option, there will only be 3 options for the resetting of the “inactivity period” (see section “Service description”). In both cases, the access to the “smart vault” will be

directly passed on to the inheritors via the details that are specified by the original asset holder.

The DigiPulse smart contract **only** transfers the access to the “smart vault” autonomously when the “inactivity period” has been reached. The access send out happens automatically to the pre-defined email address as set up by the vault creator.

## Business potential

The DigiPulse project is a unique solution for those who are involved with cryptocurrencies, but we also see that this approach can be applied to assets that are stored outside the crypto domain. There are a lot of services that deal with cryptocurrencies, but store these assets themselves (the crypto wallet is located on their servers). If the original asset holder passes away, these assets are handled through the process known as “escheatment”. There are multiple services where this approach is applied and DigiPulse could branch out with the unique “activity tracking” solution.

The secondary vision of the DigiPulse company (after the initial service has been established) would be to create an investment fund that focuses on ICO’s, thus giving back and helping the community. This approach would allow to help great ideas come to life, as our project was once in the same state.

The DigiPulse team also sees additional implications of the DigiPulse service - alternatively, the contract can be setup to send the information on it’s own if no reset has been received within a user-settable time frame - this particular method can be set-up as a “time locked” vault, that can be used as a savings fund or even a gift to someone on a specific date.

The project also can be implied by utilising a B2B2C model, regarding digital assets ranging outside of the cryptospace. The activity tracking and vault usage could be used to set up a service, that would deal with services that hold user’s assets. The service itself would be free of charge for customers, generating a large enough user base that afterwards would allow us to target companies as a subscription based service for trust validation on behalf of customers - meaning, that companies that would join the DigiPulse base, will have additional verification in the eyes of the customer and would ensure the asset continuity.

## State of the project

Currently the team is working on a private testnet version of the service and it will be available soon (updates are shared on [www.digipulse.io](http://www.digipulse.io)). The complete Alpha version will be ready by the 15th of October and the release of the public Beta will be available by the January of 2018.

One of the goals of the token sale campaign is to gather funds for the DigiPulse service to be able to gather a team of professionals, who specialise in the respective fields of IT, marketing and sales - right now we are in talks with possible candidates who would form the first addition to the existing DigiPulse team.

---

1 <https://storj.io/storj.pdf>

2 <https://www.gnu.org/licenses/gpl-3.0.en.html>

# Token holders

The Initial Coin Offering of DGPT starts on 01.10.2017 and ends on 31.10.2017. The tokens will be transferred to the users as soon as the purchase is made. The DigiPulse team will use Ethereum contract to generate the DGPT tokens. DigiPulse will provide the source code of the contract so that the exact amount of tokens will be generated and distributed. **12,700,000 DGPT** will be available for purchase from total supply of 20,483,871 DGPT. The tokens made available in the crowd fund-

ing will be standard “usage tokens”. During the token sale, we will work towards adding the token to several exchanges<sup>1</sup> and will be updating our progress on our homepage.

The token sale will be available at [www.digipulse.io](http://www.digipulse.io).

## Token sale details

The maximum amount of tokens available during the closed pre-sale and token sale	12,700,000 tokens
Token price	0.004 ETH per Token
Token ticker	DGPT
Minimum purchase per person	0.5 ETH (125 Tokens + Bonus tokens)
Maximum purchase per person	2,000,000 Tokens
Accepted currencies	ETH

The token sale will have a token reward system that will grant the earlier buyers an opportunity to acquire more tokens for the same cost. This will be set up as follows:

Token distribution priority	Token amount	Percentage rewards
Original buyers' round <sup>2</sup>	600,000	50% (incl. 200,000 additional DGPT)
1st batch	2,490,000	20% (incl. 415,000 additional DGPT)
2nd batch	2,386,250	15% (incl. 311,250 additional DGPT)
3rd batch	2,282,500	10% (incl. 207,500 additional DGPT)
4th batch	2,178,750	5% (incl. 103,750 additional DGPT)
5th batch	2,162,500	-

Each batch of tokens (and their corresponding rewards) will be available after the previous batch has been distributed.

In total there will be 12,700,000 DGPT tokens available in the token sale. The DigiPulse foundation will hold 25% of the total token supply from the token sale to sustain the future development of the service.

If the token sale campaign does not reach its maximum cap of distributing 12,700,000 DGPT, the excess tokens will be frozen for a 6 month period, after which the DigiPulse company will be able to assess them based on the demand in the market, and make the according token distributions to the exchanges, in order to stimulate the supply.

<sup>1</sup> We will work with exchanges that operate with new altcoins, such as Bittrex.com, Cryptopia.co.nz, EtherDelta.

<sup>2</sup> The “Original buyers’ round” - will be available from the 28th of September until the start of the Token sale on the 1st of October.

## Token distribution during token sale

DigiPulse will only be accepting Ethereum during the Token sale. Upon sending the amount of ETH to the smart contract, the buyer immediately receives DGPT tokens to the address from which the payment was

made according to the tier bonus currently available.

All sales from the token sale are final and no refunds are applicable if the minimum cap of 500 ETH is reached.

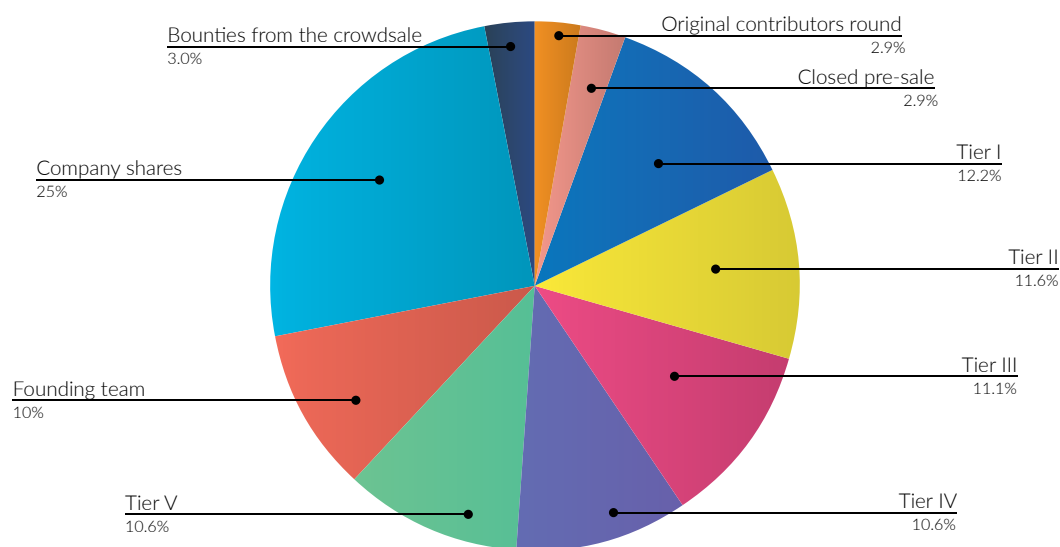

## Burning of the tokens

The unsold tokens from the token sale will be sent to address 0x00 ("burnt"). This will happen in two occasions:

- The "burning" of any unsold tokens from the 12,700,000 DGPT that were allocated for the token sale. This will take place after the "freeze period" of 6 months has ended;

- In order to maintain the company token pool to a 25% ratio from the total available token amount, the excess will be "burnt" during November, once the calculations of the Token sale results will be made.

## Bounty distribution

DigiPulse will reserve 2% + 1% of the total DGPT pool for bounties. In total that will be 614,516 DGPT. The DigiPulse team feels that it wouldn't be fair not to reward the buyers from the "1st pre-sale", since they were not covered by a refund warranty and their purchases helped us to get where we are now, we are transferring the raised amount of ETH to this token sale in the form of DGPT.

DigiPulse will offer those who participated in the bounty campaign for the 1st token sale the option to transfer their stakes on to this token sale.

**NB** the stakes from the 1st token sale will **only be redeemable** if the participation in the token sale continued in this token sale! They will be distributed on a pro-rata basis.

Token sale	DGPT amount	Percentage of total DGPT
1st pre-sale <sup>1</sup> buyers	9,617	0.05%
1st token sale bounties	195,222	0.95%
Bounties	409,677	2%

<sup>1</sup> The "1st pre-sale" took place on from the 19th - 25th of July, 2017

The bounty reward distribution will be set up as follows:

- BitcoinTalk translations for announcement: 20%
- BitcoinTalk signatures and avatar : 20%
- Quality content campaign and Referrals: 30%
- Twitter campaign: 20%
- Campaign support for different languages: 10%

Code review bounties (“bug rewards”) - during alpha and beta phases of the product launch, code review bounties will be made available. They will be paid out in ETH and the payout amount will be based on the severity of the issue. The payout amount will be **solely based on the expertise** by the DigiPulse security auditor.

## Raised fund usage

Because DigiPulse, first and foremost, is a startup, we feel obligated to use the best practices that are in place which are transparency of the team, the raised fund distribution and the overall plan and state of the project. DigiPulse is going to release quarterly statements on the fund usage and the progress of the project. This will ensure the transparency of operations and the secure custody of the funds.

DigiPulse has already acquired the attention of investors as a startup, but our team came to the conclusion that before we take on venture capital and similar investments, we want to bring this idea to the community who will be the real users of this service.

## Distribution

The hard cap for our project is set at 44'650ETH. This will provide the DigiPulse team with a runway of 5 years in which the infrastructure for the service will be finalised. By raising this amount, we will be able to

fully develop and deliver the service to the community without interruptions, as opposed to having to raise the funds necessary through investor talks and multiple funding rounds.

## Escrow

DigiPulse will have a smart contract with the minimum cap of 500 ETH that will work as the escrow for the token sale. Parameters will be embedded in the contract

that will release the funds to the holders upon reaching the minimum cap. If the token sale fails, investors have 30 days to autonomously claim their investment back.

## Fund storage

DigiPulse is going to keep the raised funds in the respective cryptocurrency wallets and is going to exchange them for fiat currencies based on the publicly available quarterly plan only to ensure that the necessary operating costs of the company are covered. We believe in the concept of cryptocurrencies and we suspect that there should be an increase in value, but we also want to protect the funds raised from token sale, hence the funds will be diversified, which in the future

could provide additional income and sustainability to our project.

The diversification of the funds will be made the following way (approximate model): 20% in fiat currency (for direct company operations); 40% in Bitcoin; 40% in Ethereum. DigiPulse might allocate funds to other cryptocurrencies in the future.

# Roadmap

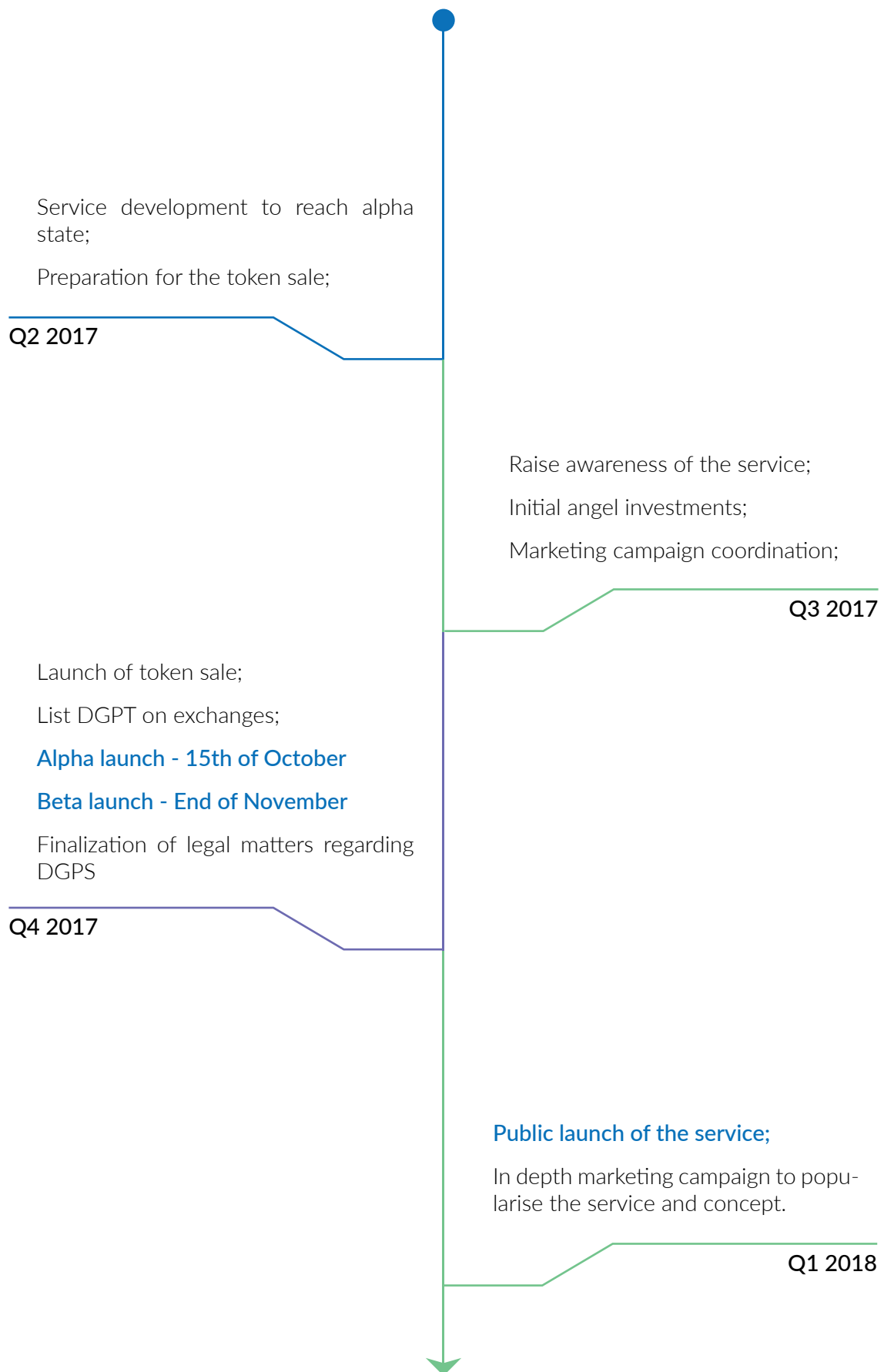

# The Company

## The background of DigiPulse

Active development of the project started in September 2016, with the initial idea of DigiPulse service focusing on API integrations which would allow inheritors to find out about services used by the vault's creator. Eventually this idea received an additional spin by adding the crypto based service Coinbase. During December 2016 the correction of the brand took place and the name changed from Unobliterate to DigiPulse to have a more meaningful and memorable name.

In February 2017, the idea was presented to investors during the TechChill event in Riga, Latvia, where the initial feedback from the investors gave us confidence that we are on the right track and that this is a problem that has not been tackled yet.

The development of the project was done during our spare time, while in parallel trying to secure funding from the European Fund "Horizon 2020". In May 2017, with the huge price spike of Bitcoin, we came to the realisation that cryptocurrencies are starting to catch up with the majority of the technologically savvy population, thus the primary focus was switched to target crypto users and leave the memorabilia side of the project as the secondary focus.

In June 2017, DigiPulse launched its pre-sale to raise funds for the marketing campaign of the token sale

that started on 4th of August. The lack of knowledge in running a token sale didn't fulfil the project to its full potential, but valuable feedback was received from the community and the problematic aspects of the project were addressed. By gaining the community's support we came up with the correct formula for the token sale and the product that all crypto users desperately seek.

The product was adjusted, the Whitepaper improved, the business plan has been fixed and the right people for the success of the project have joined the team to solve this problem in the correct way, both from a legal and a technical point of view - the way how the crypto community expects it to be solved. The launch for the second token sale attempt is scheduled for the 1st of October, 2017 with a proper plan on how to gain exposure about the project and the setting up of a marketing campaign that will reach masses.

We truly believe that Blockchain and cryptocurrencies are the future behind decentralised services, thus we are putting all our faith in the community to share our vision and support this project, so our loved ones will have our life's work available to them when each of our time comes.

# Team



## **Normunds Kvilis, Co-founder & CEO**

Prior to focusing on DigiPulse, Normunds acquired a master's degree in economics and was an analyst in a leading Scandinavian bank, focusing on financial market analysis and investment opportunities. Later, he took on the role of an IT project manager, with the focus on leading developer teams towards a bank merger. Cryptocurrencies have been on his radar for quite some time and as investor focus is starting to shift toward this investment tool, also new problems and opportunities arise.

[Linkedin](#) | [Facebook](#)



## **Dmitry Dementyev-Dedelis, Co-founder & CTO**

Before the idea of DigiPulse and the fact that we spend half of our lives online with all the assets and valuables stored there, Dmitry was working in the fundraising sector for universities. By understanding the logic behind alumni giving and gamification, and seeing it from the IT perspective, he has gained the knowledge to merge these two worlds together - digital realm and real-life behavior. To gain more in-depth knowledge about people's behaviors and their cognitive processes, he is currently managing a part-time BSc in the field of Psychology.

[Linkedin](#) | [Facebook](#)



## **Rafik Misirov, Legal advisor**

Rafik's master's degree in law enables him to operate within multiple venture frameworks. With a portfolio including an EU project in Azerbaijan on pension funds, Rafik currently executes projects related to social entrepreneurship. Having set his sights on the area of investment strategy, Rafik is currently supplying his legal know-how as part of DigiPulse.

[Linkedin](#) | [Facebook](#)



## **Steve Walschot, Early adaptor of the blockchain, security auditor**

Known as one of the top security auditors in EU, Steve started out by teaching himself more than 12 programming languages that in turn lead to his first profitable code creation at the age of 16. Nowadays, Steve's focus has been set to cryptocurrencies. While helping out multiple companies with penetration tests and security expertise, he has also kept his sights on the newest developments in the blockchain domain, which in turn lead Steve to find and join the DigiPulse project, truly believing in the idea that the project aims to bring to the community.

[Steemit](#)





### **Maija Anna Ludbarza, Communications and Community**

Fascinated by the dynamically changing startup environments that are often fertile grounds for creative problem solving, Maija's strength lies in her fields of expertise - Communications, Public Relations and Copywriting. Passionate about team spirit, community building, and creative communications, she is committed to supporting the team in their mission.

[Linkedin](#)



### **Janis Zaltans, Project Manager**

Interested in all startup related activities and innovations, until recently Jānis was coordinating marketing campaigns for the Business Incubator of the University of Latvia. Apart from organizing Idea Pitches and success story events, Jānis also operated as a startup mentor, helping teams identify and reach their potential target markets.

[Linkedin](#)



### **Eduards Egle, Lead Developer**

Hard-working, supportive and dedicated, Eduards constantly livens the office with his 5-cent humour.

[Linkedin](#)

## Advisors



### **Cristobal Alonso, Senior Advisor**

An experienced Serial Entrepreneur, Global Executive and Insead MBA, Cristobal is famous for making company strategy and vision a reality through operational fulfilment, technology, and people management. In between running Startup Wise Guys - one of Europe's leading B2B Startup Accelerators and his other versatile engagements, Cristobal has joined DigiPulse as a Senior Advisor, expediting the company's growth with his expert knowledge of all things VC, Funding, Angel Investors, product positioning and strategy.

[Linkedin](#)

# Revisions to white paper

## Revisions to version 2.0.1

- Removed - Accepted currencies throughout the token sale campaign are BTC, ETH and LTC. Depending on the currency in which the buyer wants to buy DGPT, different flows are set up.
- Added - "Original buyers' round".
- Changed - DGPT profit sharing
- Changed - DigiPulse offers the opportunity for 10,000+ DGPT tokens to change their tokens into DGPS, that is eligible to receive profit sharing from the incoming tokens.
- Changed - The token distribution amongst tiers.

## Revisions to version 2.0.2

- Changed - the date of the Alpha launch to the 15th of October;
- Changed - Beta release moved to January 2018.

## Revisions to version 2.1.0

- Changed - token circulation changed for storage provider payouts to be tied to EUR exchange rate;
- Changed - the price mechanism for the asset timestamp release will be tied to a fiat currency (e.g. If the service will cost 5 EUR, then you need to pay the corresponding amount of DGPT tokens based on the exchange rate);
- Added - burning of the tokens.